

INSULSPAN®

STRUCTURAL INSULATING PANEL SYSTEM

Better building ideas from PFB™



Installation Guide

East - 1.800.726.3510

West - 1.866.848.8855

www.insulspan.com

NOTE: Insulspan continuously updates its materials. For the most current versions, check the Specifying SIPS and Technical Product Information at www.insulspan.com.

Table of Contents

1.	General Information on Insulspan SIP System.....	3
1.1.	Insulspan SIP System.....	3
1.2.	Insulspan SIP Construction.....	4
1.3.	Insulspan SIP System – Options.....	4
1.3.1.	Fabricated Panels.....	4
1.3.2.	Ready-to-Assemble Panels.....	5
1.4.	Design Requirements.....	5
1.5.	Insulspan SIP System – Delivery Preparation.....	6
1.6.	Additional Considerations.....	9
2.	Design Considerations.....	11
3.	Panel Connections.....	13
3.1.	OSB Surface Spline.....	13
3.2.	Insulspline.....	14
3.3.	Dimensional Lumber or Engineered Wood.....	14
3.4.	Insulspan Screw Fasteners.....	15
4.	Wall Panel Installation Details.....	17
4.1.	Base-of-Wall Details.....	17
4.2.	Bottom Plate Attachment to Sub-Floor Sheathing.....	19
4.3.	Preparation for Panel Installation.....	20
4.4.	Corner Panel Installation.....	21
4.5.	Installing Subsequent Wall Panels.....	22
4.6.	Window and Door Panel Openings Installation.....	23
4.7.	Let-in Top Plate Installation.....	24
4.8.	Upper Wall Details.....	24
4.9.	Beam Pockets.....	28
5.	Roof Panel Installation Details.....	29
5.1.	Before Lifting Any Roof Panels.....	29
5.2.	Roof Panel Support Requirements.....	30
5.3.	Hoisting Panels.....	32
5.4.	Ridge Details.....	32
5.5.	Valley Details.....	34
5.6.	Roof Overhangs.....	34
5.7.	Roof Penetrations.....	35
5.8.	Eave and Gable End Finishing Details.....	38
6.	Floor Panel Installation Details.....	40
7.	Wiring and Plumbing.....	41
7.1.	Wire Chases.....	41
7.2.	Receptacle Boxes.....	43
7.3.	Plumbing Lines.....	45
8.	Special Sealing Details.....	46
9.	Exterior Finishing – Wall and Roof Applications.....	48
9.1.	Rain Penetration Control.....	48
9.2.	Wall Cladding.....	48
9.3.	Roof Cladding.....	49

9.4. Interior Wall and Ceiling Finishing 50

Appendix A - Applying Expanding Foam Sealant.....51

1. General.....51

2. Application Instructions51

3. General Storage and Handling Notes52

Appendix B - Panel Seal Tape Installation Instructions53

1. Background53

2. Surface Preparation53

3. General Tape Installation Tips53

4. Panel Joint Sealant Tape Location53

5. Installation Sequence54

5.1. Prior to Roof Panel Installation..... 54

5.2. Fully exposed seams 54

5.3. Concealed seams..... 54

5.4. After Panel Installation 55

5.5. Roof-Wall Intersections with Support Members..... 55

1. General Information on Insulspan SIP System

This manual covers the details commonly encountered with the Insulspan structural insulated panel (SIP) system in residential and commercial construction applications. It is intended as a general guide only. Be sure to follow the specific instructions shown on Insulspan SIP System shop drawings and the manufacturers of any other building products that interface with the Insulspan SIP System, as well as all applicable building codes. This manual shall be used with training provided by Insulspan Site Advisors, Sales Representatives and/or the Insulspan dealer network in conjunction with the architectural and engineering drawings and specifications. (An Insulspan representative can assist with applications using the Insulspan SIP System.)

QUALITY, SERVICE AND EXPERTISE

INSULSPAN takes these three words seriously. Please make sure you contact your sales representative if you require any assistance prior to starting your building project. We offer trained Site Advisors that can work with you and/or your contractor in the field to guarantee your project is completed to your specifications.

1.1. Insulspan SIP System

The Insulspan SIP System represents a revolution in building technology. The large, easily assembled panels make it possible to erect houses and other buildings quickly and with minimal expense. By spreading the structural loads out over large areas, the many individual studs used in stick-framing can be eliminated. In addition to reducing site labor and construction time, the panel technology is ideal for creating air-tight, highly energy-efficient buildings.

Insulspan SIPs are composed of molded expanded polystyrene (EPS) insulation sandwiched between interior and exterior skins of oriented strand board (OSB). By integrating the EPS insulation with exterior and interior OSB sheathing, labor requirements for construction are greatly reduced. The EPS insulation core can include standard horizontal and optional vertical wiring chases incorporated during the factory lamination process, which make it a simple task to run wires in panel walls and ceilings.

Because Insulspan SIPs are made from large, carefully connected sections, most of the air leakage through the wall assembly associated with stick-frame construction is eliminated. In addition, the layer of EPS insulation in the panels is continuous, interrupted by very few framing members. This continuity of the insulation greatly improves the overall thermal performance of the building envelope as compared to stud frame construction. These properties make Insulspan SIPs ideal for constructing tight, energy-efficient buildings.

Insulspan SIP system when used as bearing walls are much stronger than stud walls installed in comparable thickness. This strength is similar in principle to the

properties of an “I-beam”, in which the strong top and bottom flanges (OSB) are joined by a web (EPS insulation core), thus providing stiffer walls.

Insulspan SIPs can also be used to enclose a structural frame. When Insulspan SIP walls are attached to a structural framework they are sometimes referred to as “curtain wall” panels. Some buildings incorporate elements of both bearing wall panels and curtain wall panels. These hybrids have the efficiency of a structural panel building, and they can take advantage of timber framing or other framing methods for aesthetic or special load-bearing needs.

1.2. Insulspan SIP Construction

Insulspan SIPs have oriented strand board (OSB) skins on both the interior and exterior side of the molded expanded polystyrene (EPS) insulation core (**Figure 1**). For wall applications, the SIP must be finished on the interior with drywall or other code approved 15 minute thermal barrier that protects the foam. These panels have been evaluated to confirm compliance with code requirements.

The standard OSB skin thickness is 7/16 inch. The interior and exterior skins are typically the same thickness. Insulspan SIPs are available in standard overall thicknesses of 4 ½”, 6 ½”, 8 ¼”, 10 ¼” and 12 ¼”.

Most roof ceiling applications also require drywall or other code approved thermal barrier. Consult your local code for requirements related to your application. There are some exceptions in the codes that can be reviewed if it is an important design criterion. Consult your Insulspan sales representative for additional information.

Figure 1:

*INSULSPAN
Structural Insulated
Panels*

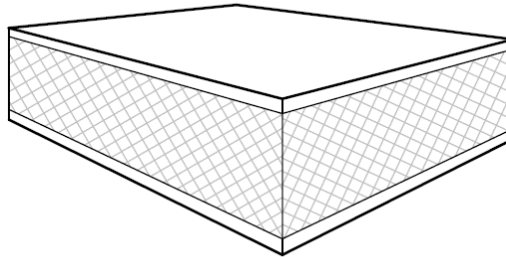

1.3. Insulspan SIP System – Options

1.3.1. Fabricated Panels

Fabricated Panels are provided custom cut to match with your design. All panels are specifically shaped for your project and come to the job labeled and ready to start assembly. Fabricated Panels will still need to have the connection splines and any structural lumber installed on site. One advantage to this system is that modifications can be made to the panels much easier than if the lumber is already installed.

In general, no fabrication of panels is required in the field. If minor modifications are required as a result of differences between the drawings and the actual on-site

conditions, these modifications need to be incorporated into the approved Insulspan shop drawings. Before panels are modified on site, an Insulspan representative should be consulted to ensure structural aspects are considered.

1. Fabricate Panels allows you to manage your work force and keep work in the field for your crews versus having the connection splines and any structural lumber completed by the manufacturer.
2. Since minimal or no field fabrication of the panels may be required, assembly of the panels can start immediately.
3. The Fabricated Panels process gives you full review of your project-specific Insulspan shop drawings for your approval prior to manufacturing.

1.3.2. Ready-to-Assemble Panels

The Insulspan SIP System is available as an industry-leading ready-to-assemble (RTA) building system that gives builders an additional competitive edge over traditional stick frame construction.

The advantage to this system choice is that it has panel connection splines and structural lumber installed where possible. It does not eliminate the need for assembly in the field of panel components required to create openings such as windows and doors.

1. RTA Panels reduce construction time in the field.
2. Improves efficiency in construction scheduling.
3. Integrates all architectural and structural elements.
4. Reduces construction loan financing time.

1.4. Design Requirements

Architectural and engineering drawings for your project are utilized by our drafters to create Insulspan shop drawings of the panels for your review and approval. This is a process that requires review by your design team and must take place in a timely manner. This review guarantees that the panels that are delivered to the job match your design intent and the engineering requirements. This design review process is critical. Therefore, it is very important the person responsible for signing off on the drawings is experienced with shop drawings and comfortable with the process.

This process can be expedited by making sure that the project drawings provided at the outset of the SIP drafting process contain all pertinent information for the project including, but not limited to the following:

1. Complete floor plans with dimensions.
2. Complete elevations with floor to floor and top of plate dimensions.
3. Building section showing dimensions and connections.
4. Window schedule with rough opening sizes and header/sill heights.
5. Foundation plan with details and dimensions.
6. Structural engineering design requirements and calculations, if available.

Providing this information will ensure that the approved shop drawings contain all of the correct elements prior to the panels being manufactured.

1.5. Insulspan SIP System – Delivery Preparation

SITE ACCESSIBILITY

Panels are typically delivered to site with conventional highway tractors and 48' trailers. Heights of trailers are usually 13'6" as measured from the road surface. Once the delivery truck leaves the major highway there are many additional items to consider

- Driveways
- Culverts
- Bridges
- Sharp turns
- Hills
- Trees
- Overhead Wires
- Buried lines or tile
- Excavation trenches

If the tractor trailer cannot get into the site, be prepared to unload onto a smaller delivery vehicle and then shuttle the panels into the jobsite. If this is required then additional trucking time should be allocated. Be sure to identify any potential concerns related to shipping or access to your jobsite to the shipping company.

MATERIAL HANDLING EQUIPMENT

Arrangements will need to be in place prior to the SIPS arriving on the site. Each installation will require specific site considerations for unloading. There will also be requirements for the tools & equipment needed for installation, which could include rigging and lifting tools required for larger panels.

Shipping companies generally allow for 2 hours offload time. After this the hourly rate can be expensive and will be charged to the receiver of the shipment. Therefore, it is important that the on-site personnel are prepared to offload the panels quickly and efficiently.

Unloaded panels take up lots of room on site and need to be planned for carefully. Room for sorting panels is often necessary because the first panel required is not always where you expect it to be.

Unloading of the shipping truck will require that the following items be considered prior to the arrival of the truck at the site.

- Panels come in large, mixed piles to maximize the trucking load for shipping efficiency
- A single panel can weigh 200 to 800 pounds for sizes from 4' by 8'to 8' x 24'

- Manpower: Crew of 4 to 5 is best
- Crane or forklift selection will depend on the site terrain and the working distance
- Crane bars or fork extensions
- Lifting plates
- Scaffolding
- Extension ladders
- Wood blocking to support panels on site and protective cover materials for rain protection of SIP package prior to installation start

SIP construction is compatible and can be used in conjunction with stick framed, timber framed and insulating concrete form (ICF) structures, as it performs as a standard building product. To install, shape or modify the SIP, the installer utilizes the basic construction techniques that any construction professional would be familiar with having worked with other building products.

Tools can be divided into four categories as noted below:

PERSONAL TOOLS

1. Tool belt
2. Hammer
3. Tape measure
4. Utility knife
5. Pry bar
6. Nail puller
7. Wood chisels
8. Plumb bob
9. Awl
10. Chalk line and chalk
11. Dry string lines
12. 4 foot level
13. Hand saw
14. Adjustable wrench
15. Framing square
16. Framing square gauges
17. Linesmen pliers or equal
18. Lumber crayon & pencil

CONTRACTOR SUPPLIED TOOLS

1. Electric drills
2. Cordless drills
3. Drill bits & augers
4. Power circular saws
5. Chain saw
6. Reciprocating saw
7. Saw blades for each saw
8. Power cords
9. Sledge hammers
10. Portable router and bits
11. Air compressor & hoses
12. Pneumatic nail or staple guns
13. Nails or staples
14. Clamps
15. Ratchet straps
16. Scaffolding, planks & ladders
17. Caulking guns
18. Builders level or transit

PANEL SPECIFIC TOOLS & ACCESSORIES

1. Foam scoop – to provide recesses on the edges of panels where required
2. Portable hot wire assembly – used to remove long sections of foam
3. Chain saw guides
4. Insulspan Approved Panel Screws
5. Insulspan Approved Sealant
6. Insulspan Approved 2-Part Polyurethane Foam Sealant

7. Insulspan Approved Panel Seal Tape
8. Insulspan Approved Roof Panel Edge Sealant

SAFETY EQUIPMENT

Safety can not be over-emphasized on any construction project. Regular daily safety meetings at the start of each day can help avoid many of the injuries that occur on any jobsite. Safety equipment will be state or province specific and all rules and guidelines must be followed.

1. Written fall protection plan
2. MSDS (Material Safety Data Sheets) reports
3. Hardhats as required when there is any overhead work
4. Eye protection glasses
5. Hearing protection
6. Safety harnesses
7. Any other PSE (Personal Safety Equipment) required such as gloves, boots, etc...

FOUNDATION AND FLOOR AREA VERIFICATION

- Length and width dimensions
- Square
- Level
- The closer the floor is to square, level and correct in dimensions, the fewer problems you will have installing panels
- Advisor Service scheduling
- Advisor will provide a safer installation by:
 - Reducing installation time
 - Ensuring a quality job
 - Providing training for repeat customers

1.6. Additional Considerations

For proper performance and safety with the Insulspan SIP System, the following minimum guidelines must be followed:

- **Storage and Protection of Panels.** Panels must be kept dry during storage. Keep SIPs stacked off the ground on level blocking to prevent warping or twisting. Panels need to be protected from moisture exposure during storage on the jobsite and must be protected as soon as practical after they are installed. For roof applications, temporary protection can be provided using materials such as single or multiple layers of 15lb or 30lb felt paper which complies with ASTM D226 (NOTE: If the temporary protection is intended to be incorporated as part of the finished roof cladding system, you must ensure compatibility with other roof membrane components).

The appropriate type of temporary protection will vary based upon anticipated wind-driven rain, snow and ice condition in your geographical location. If you are building a large roof structure you will have to protect sections of the construction as the panels are installed. **If the exposed OSB skins of the Insulspan roof**

SIP become wet during construction, they must be allowed to dry before the asphalt shingles are installed since any wetted OSB cannot dry towards the attic, as in conventional construction.

- **Mechanical Ventilation.** Due to the typical low air infiltration rate, it is critical that the whole house ventilation system be designed to maintain indoor air quality and control interior humidity levels. We recommend that heating, ventilation and air conditioning (HVAC) system design be reviewed by a HVAC design professional familiar with SIP construction. Insulspan Product Information Bulletin No. 206 provides additional guidance on this issue.
- **Assembly.** The Insulspan SIP System is designed for strength and durability. To benefit fully from the panel strength, panels must be properly secured to each other. Secure panels firmly at all joints and intersections using the connection details found on the Insulspan shop drawings for your project. Typical construction details that address a variety of applications are also found in this manual. Attach panels firmly to all wood framing members which they contact. Follow fastener length and on-center spacing requirements on the Insulspan shop drawings precisely. Special loading situations will require additional engineering, review and consideration.

2. Design Considerations

Insulspan SIP installation can be greatly simplified by careful planning at the outset. Jobsite waste can be kept to a bare minimum by designing the structure for optimal use of the Insulspan SIP system. Follow these general guidelines, and contact your Insulspan sales representative, Insulspan authorized dealer or Insulspan preferred builder if you have questions or need additional information. The most up-to-date engineering data for the Insulspan SIP system can be obtained from our website (www.insulspan.com) under For Professionals section within the Research Center tab.

- Consider **SIP standard dimensions** when working on your building design. To minimize waste, design the structure so that the on-center spacing of panels is a multiple of 4' (i.e. 4', 8', 12', etc.). Account for SIP overlap at corners when designing the spacing. To do this, you need to know the thickness of the panels you will use.
- **Plan window and door placement** relative to panel spacing within the design to simplify SIP installation. Doors normally need full blocking support extending the full height of the SIP on either side of the rough opening, so it makes sense for full SIPs to abut the door opening (**Figure 2**). The same holds true with large windows. Refer to Chapter 4 of this installation guide for more information on detailing around window and door openings.
- **Joists and rafters** can be solid 2x lumber or approved engineered lumber joists such as Weyerhaeuser TJI® wood I-beams or Parallam™ engineered lumber. When using these advanced products, be sure to follow product manufacturer's design specifications regarding drilling, notching, and nailing of joists.
- Insulspan **Product Information Bulletins** are available in the Insulspan Design Manual and from our website (www.insulspan.com). These bulletins should be consulted as part of design process as they provide important product updates related to the design and installation process.

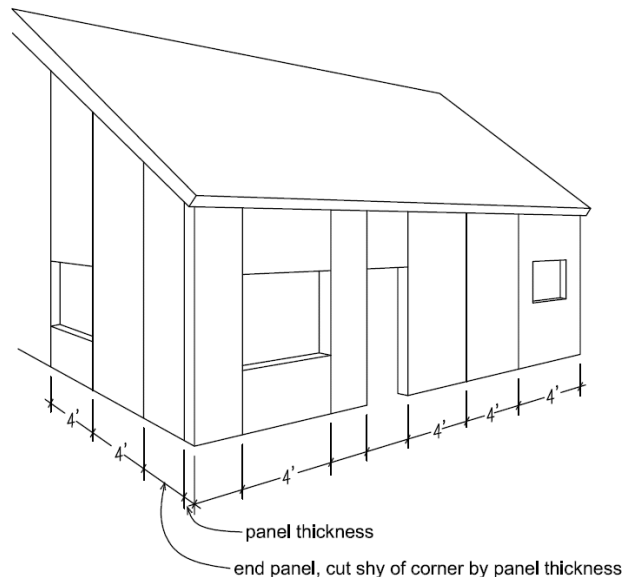
Figure 2:*Optimizing panel use*

- The use of **rain screen management techniques** for walls is now required for wall assemblies by codes in certain jurisdictions. Design requirements for wall cladding systems must consider local environmental conditions and assembly restrictions as defined in applicable building codes. General information is provided for reference in this installation guide.
- **Cladding attachment** requirements should be verified with cladding suppliers. Specific fastener pullout resistance required for the cladding attachment should be reviewed during the design phase. Insulspan can provide pullout resistance for attachment to OSB skins.
- **Tongue and Groove interior finishing** can be combined with the Insulspan SIP System. However, special consideration must be given to address the requirement for a vapour barrier where required on the interior of the roof assembly. Design of roof systems must consider local environmental conditions as defined in applicable building codes. For T and G applications where T and G is installed after the Insulspan SIP panels are installed, ensure that the properly sized shim is installed in a structural manner.
- **LEED, Energy Star and Built Green programs** may require special design considerations such as the use of approved low VOC assembly materials in SIPs building projects. Builders need to check with their clients to ensure they have all the approved materials to meet the project LEED rating objectives.
- **Measures to control insect infestations** must be considered. Refer to Insulspan Product Information Bulletin 205 for general recommendations on good building practices that builders and home owners can follow in areas where infestation by pests like carpenter ants and termites is possible.

3. Panel Connections

Panels must be structurally fastened at the joints to ensure the integrity of the wall and roof system. This section provides joining techniques that are most commonly used. Additional structural design considerations for transverse, racking or axial capacity can dictate the type of connections that must be used. Insulspan SIP System design requirements for your specific project will determine the appropriate connection system. **For nailing through panel skin into OSB splines or into 2x lumber at panel joints, use nail schedule as per approved Insulspan shop drawings.**

3.1. OSB Surface Spline

One method of connecting panels is use of an OSB surface spline (**Figure 3**). The 7/16" x 3" OSB splines fit into pre-routed recesses and the panel skins are attached to the OSB splines per nailing schedule on approved Insulspan shop drawings.

All spline materials must be kept dry before and during installation. **Do not install wet or frozen OSB splines.**

Figure 3:
OSB surface spline connections

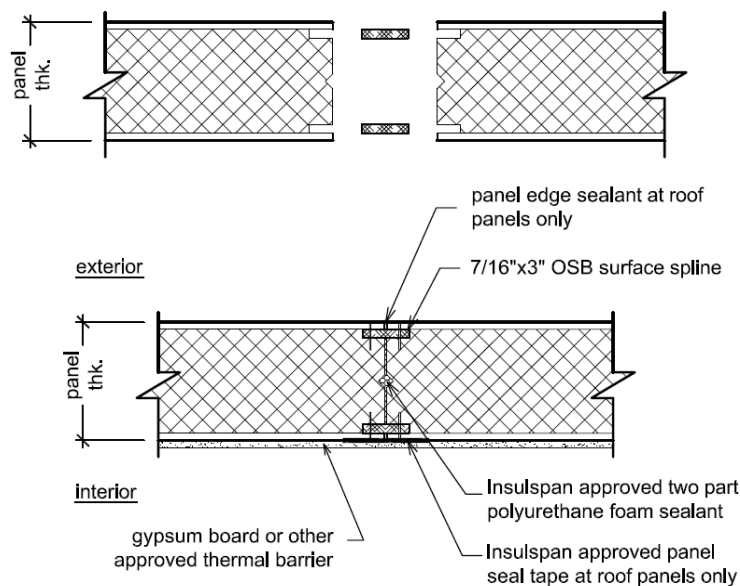

When cutting the recess for the OSB surface spline, a foaming channel is cut at the center of the foam. To ensure a tight seal at the joint (**Figure 4**), after the panels are joined with the OSB surface spline inserted, drill holes from the outside every 12-18" to access the foam channel. Next, spray Insulspan 2-part polyurethane foam sealant into every other hole so that air in the channel can escape as the foam expands and so that one is confident that the channel is filled. The exact space of holes and duration of foam spraying will depend on the specific foam used and the climatic conditions at the time of application. See Appendix A for more information on foam installation instructions. After the joints are sealed, nail as per design tables and construction documents.

Figure 4:

Applying expanding foam sealant

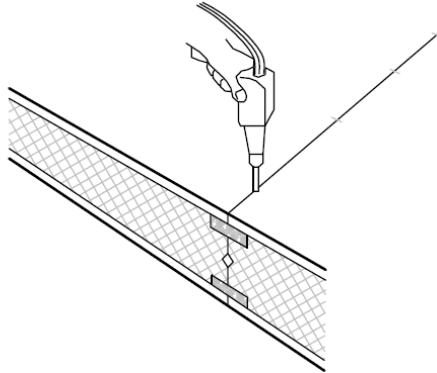

3.2. Insulspline

Another type of connection to join panels is the Insulspline connection (**Figure 5**). The EPS insulation along the edge of panels to be joined is recessed approximately half the thickness of the connection material. Insulspan approved sealant is applied in locations shown in **Figure 5** and the Insulspline is inserted and nailed in place through the OSB skin.

The fastener schedule is important to developing allowable loads found in Insulspan design tables. See design tables and construction documents for specific fastener types and schedules.

Figure 5:

Insulspline connections

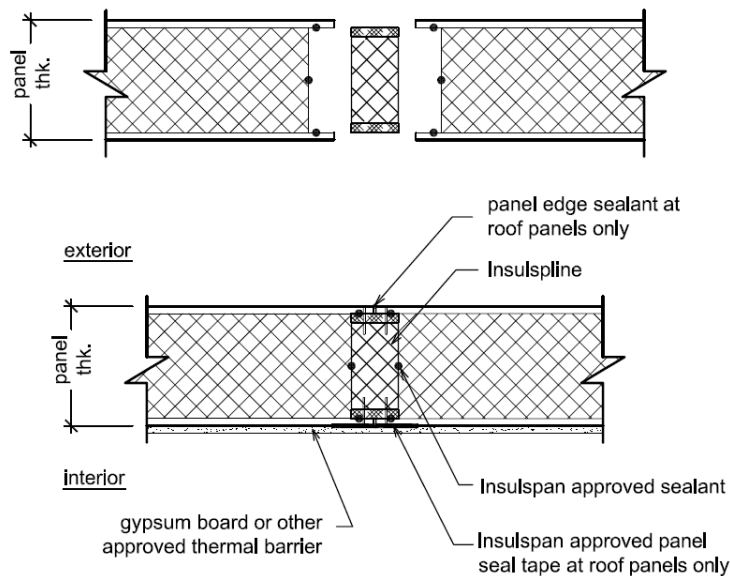

3.3. Dimensional Lumber or Engineered Wood

Another common panel joining system is the use of a 2x dimensional lumber or engineered wood connection (**Figure 6**). The EPS insulation along the edge of panels to be joined is recessed approximately half the thickness of the connection material. Insulspan approved sealant is applied in locations shown in **Figure 6** and the 2x lumber is inserted and nailed in place through the OSB skin.

The fastener schedule is important to developing allowable loads found in Insulspan design tables. See design tables and construction documents for specific fastener types and schedules.

Figure 6:

2x lumber or engineered wood connection

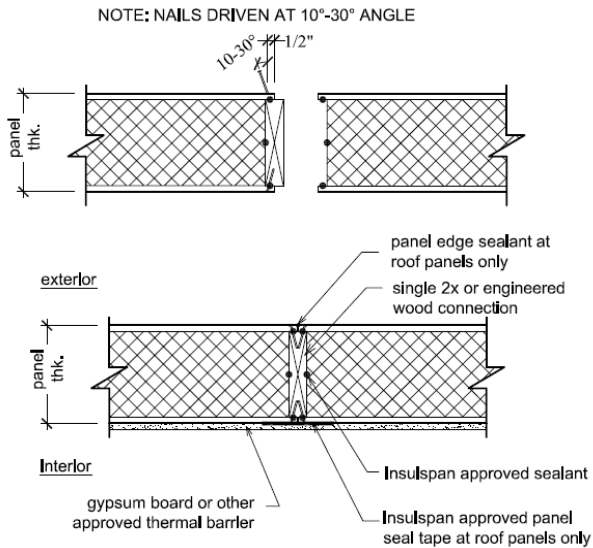

When required, a double 2x dimensional lumber or engineered wood connection can be used to join the panels (**Figure 7**).

Figure 7:

Double 2 x lumber or engineered wood connection

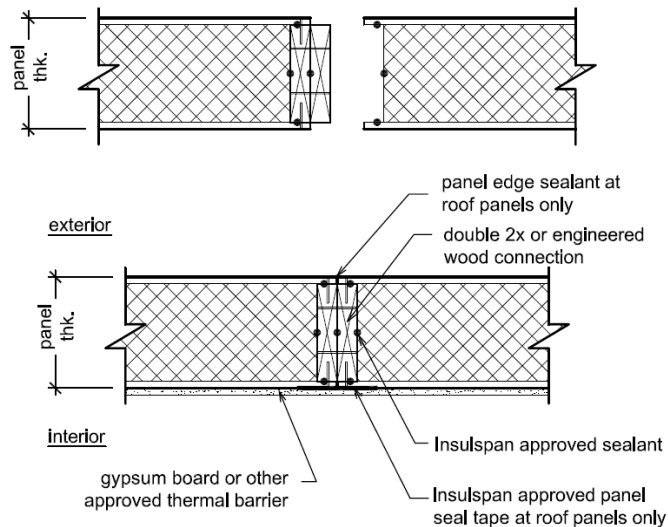

3.4. Insulspan Screw Fasteners

When panel joints are supported by structural members, attachment of panels is accomplished with Insulspan screws. The length of fastener required would depend on the thickness of the panels you are using per the screw schedule below. Space screws wherever the panels rest on structural framing members as dictated by the Insulspan shop drawings. To make it easier, screws may be screwed partway through the panels before lifting them up into place (**Figure 8**).

Figure 8:

Installing roof panel with screws in place

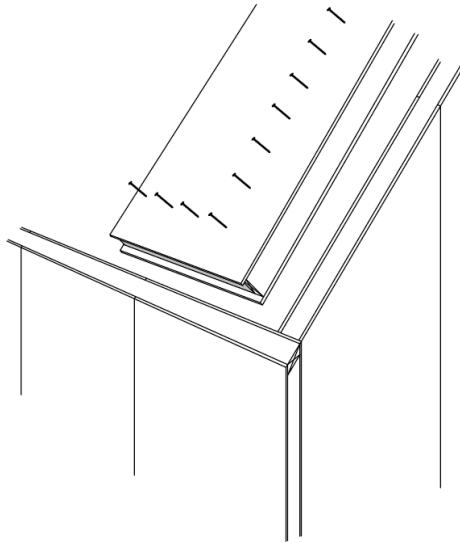

IMPORTANT NOTE: The screws used to attach panels are a special high strength fastener which has been heat-treated to case harden the exterior of the screw while maintaining a ductile core. **Striking a screw with a hammer may cause a hairline crack to form in the case hardened portion of the screw which will significantly weaken the screw.** Therefore it is critical that screws not be driven with a hammer. To more easily get the screw through the panel and started into the supporting member, one can either pre-drill a hole with a bit 1/32" diameter larger than the screw shaft or pre-punch a hole, through the outer skin with a similar sized spike.

Screw Schedule

For direct attachment of panels into external structural members or into other panels at corners and wall-ceiling intersections use screws as listed.

Panel Thickness	Screw Length	Typical Spacing
4 1/2"	6"	12"
6 1/2"	8"	12"
8 1/4"	10"	12"
10 1/4"	12"	12"
12 1/4"	14"	12"

Note: When shims or spacers are used between the Insulspan SIP and external structural members screw length shall be adjusted to ensure minimum 1" penetration into the external structural member.

4. Wall Panel Installation Details

Wall panels are installed vertically, with several different connection details available. The detail to be used will depend on factors such as panel thickness, foundation wall thickness, wall height, and floor framing details.

Starting with a square and level foundation is a key to good results, especially when building with Structural Insulated Panels. There needs to be effort and attention to provide accuracy at the foundation level, otherwise the panel installation process will be impacted.

Correctness of foundation with respect to level, squareness, and overall dimensions ensure that there is full bearing for both panel skins and the floor joist.

If there are discrepancies in the foundation from the approved plans, they should be resolved prior to framing the first floor deck. Failure to conform to the approved plans can cause many adjustments in the wall panels.

When roof panels or pre-engineered trusses are used for the roof framing, small discrepancies can create large variations that might require additional panel adjustments and/or framing members.

Depending on the size of the wall panels, lifting equipment may or may not be required. The average weight of Insulspan SIP wall panels is 4 lbs per square foot, so the installer should consider this fact before panel installation commences. Even header panels, although dimensionally small, can be very heavy.

4.1. Base-of-Wall Details

Panels can be supported on the foundation wall where foundation wall thickness allows room for both the wall thickness and adequate bearing for the floor joists (**Figures 9 and 10**). The bottom edge of panels are routed out to a depth of 1-1/2 inches to receive the 2x edge blocking which is used to anchor the panel to the sill plate.

Figure 9:

Sill detail— panel resting on foundation wall

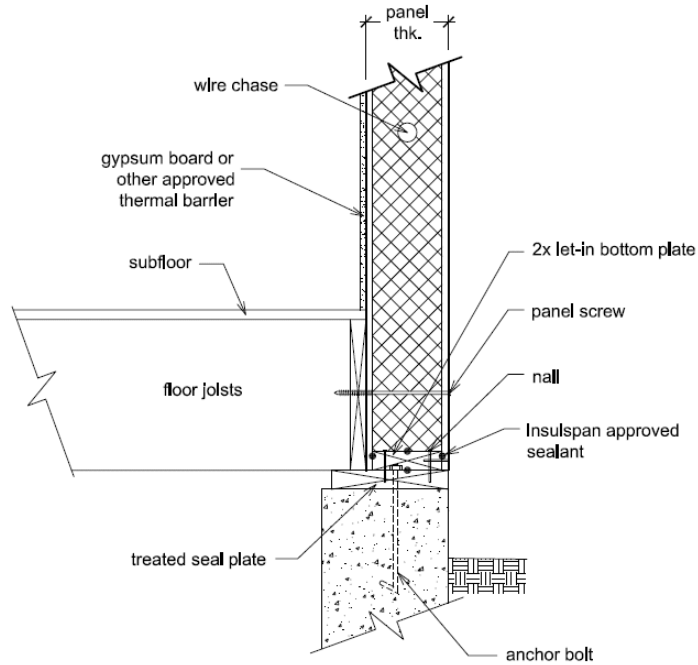
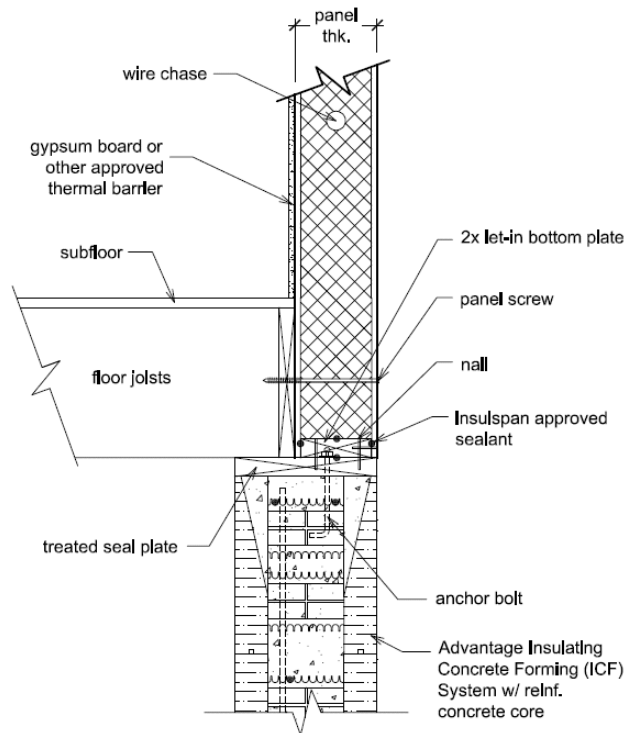

Figure 10:

Sill detail— panel resting on ICF foundation wall



IMPORTANT: Always check treated sill plates for square and proper wall length.

Another option is to construct the floor deck so that the rim boards are flush with the outside of the foundation (conventional framing practice), and set the wall panels on the floor deck as described above (**Figures 11**).

Figure 11:

Sill detail—panel resting on floor deck

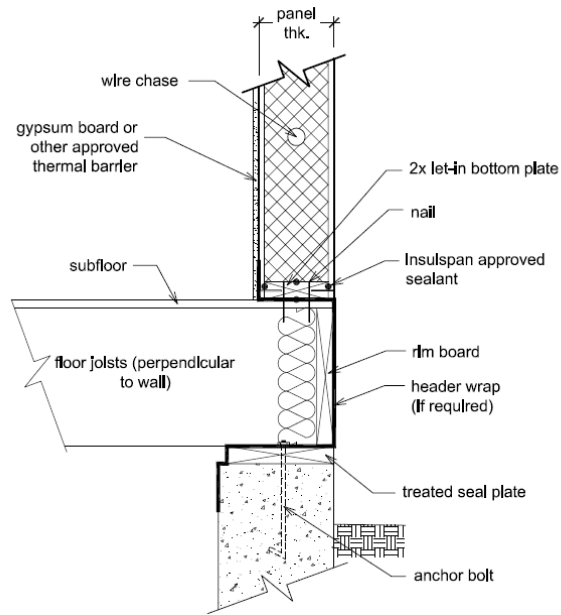

4.2. Bottom Plate Attachment to Sub-Floor Sheathing

1. Check sub-floor dimensions against Insulspan shop drawings to determine start point. Use the 3-4-5 squaring method to ensure the sub-floor is square.
2. Measure in 1/2 inch at the selected start point.
3. From this start point, you will need to snap a chalk line around the entire perimeter of the sub-floor to set the bottom plate (**Figure 12**).
4. The line should end up 1/2" minimum in from the edge of the sub-floor sheathing around the entire perimeter. Note: To achieve design structural performance of the Insulspan SIP system both OSB skins must be fully supported.

**Figure 12:**

Snap a chalk line

5. Apply one 5/8" bead of construction adhesive (e.g. PL 400) along the inside perimeter of the snapped chalk line where the bottom plate will be set.
6. Lay the bottom plate into position on top of construction adhesive and nail or screw down to the sub-floor sheathing as per Insulspan shop drawings. Make sure fasteners penetrate the sub-floor sheathing into floor joists for a strong connection.
7. Continue this procedure around entire perimeter. At corners, refer to Insulspan shop drawings to ensure correct placement of bottom plate. One bottom plate will

always run through to the end of the sill plate or sub-floor, while the other bottom plate coming into the corner will be stopped back 1/2" to allow the inside OSB wall sheathing to carry through (**Figure 13**).

Figure 13:

Corners



Note: When installing bottom plates over treated sill plates on ICF foundations, concrete foundation walls or slab, the same procedures will apply.

4.3. Preparation for Panel Installation

Before tilting panels over the bottom plate check the bottom of panels for vertical wiring chases. Be sure to measure in corresponding distance along bottom plate. (**Figure 14**)

Figure 14:

Marking and drilling wire chases



Drill a 1-1/2" diameter hole through the plate and sub-floor sheathing. Clear all drilling debris. Mark these positions on the sub-floor sheathing for later reference.

Figure 15:

Insulspan panel sealant application



Apply a consistent (unbroken) 3/8" bead of Insulspan approved sealant along both inside corner edges of bottom plate (**Figure 15**).

4.4. Corner Panel Installation

Before setting wall panels in place, clear any debris that may have lodged in spline grooves or recessed areas of the panels. Also, check OSB skins for damage and repair these areas. Report any serious damage to your Insulspan sales rep for repair instructions.

Once the bottom plates have all been set in place, wall panel installation can begin. It is imperative to start in a corner and work out in either direction. The corner you decide to start in may be determined by many factors, such as crane access or job site conditions. Regardless, it is important that the first corner is set accurately and that both wall panels at the corner are plumb and square.

Both corner panels have 2x let-in blocking in their edge (**Figure 16**). Fasten bottom edge of first panel to bottom plate using nails on both sides of panel spaced as per approved Insulspan shop drawings.

Figure 16:

Typical corner

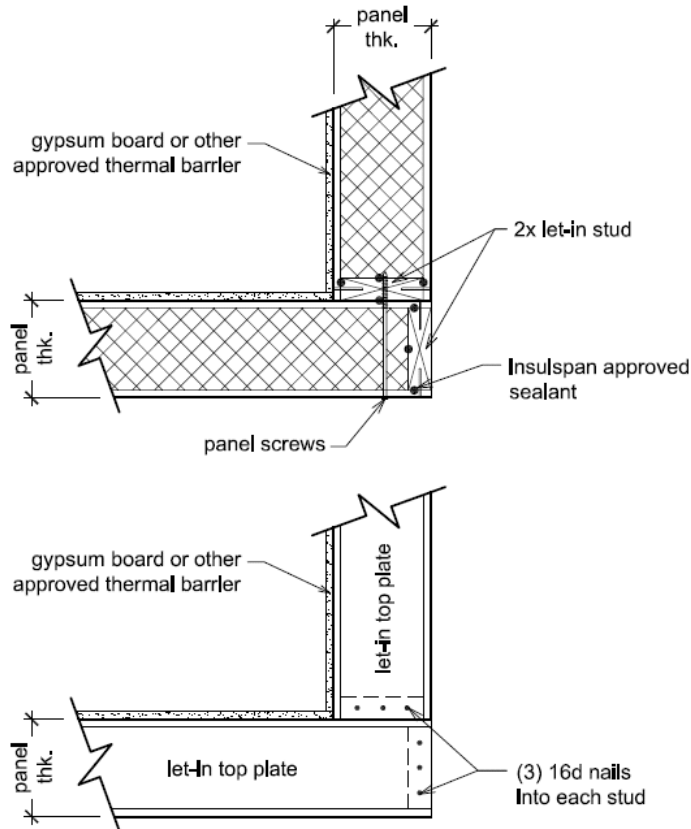

For timberframe construction, both corner panels must be fastened to the timber posts with Insulspan approved screws as per approved Insulspan shop drawings (**Figure 17**).

Figure 17:

Typical timberframe corner

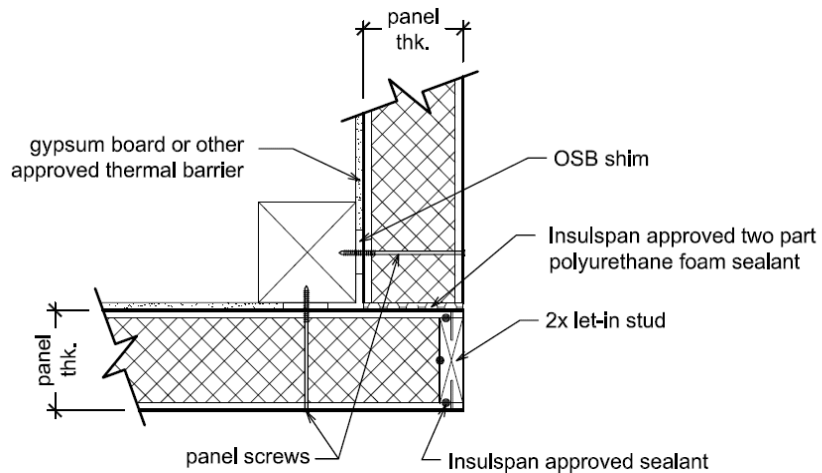

Before placing adjacent panel to form the corner, apply a 3/8" bead of Insulspan approved sealant along the OSB interior surface of the panel that will contact the edge plate of the adjoining panel.

Tilt panel into position over the bottom plate, being careful not to disturb the sealant bead. Before fastening the panel in place, use a level on the interior surface and end of the panel to ensure that it is vertically plumb. Install the adjacent panel to form the corner (**Figure 18**).

Figure 18:

Installing corner panels

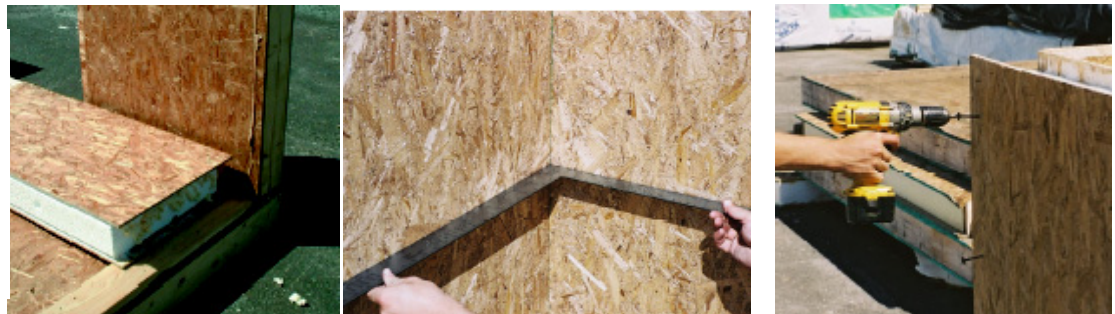

Before fastening the panels in place, use a framing square and level on the interior surfaces of the panels to ensure that they are vertically plumb and the corner is square. Use Insulspan approved panel screws with 2" metal washers to fasten the panels to each other. The Screw Schedule in Chapter 3 provides a common spacing, but the approved Insulspan shop drawings will take precedence on each individual project.

Once a corner has been set in position it is easy to progress in both directions with the successive panels.

4.5. Installing Subsequent Wall Panels

Before installing successive panels into position, remember to apply Insulspan approved sealant along both inside corner edges of the bottom plate and the panel to panel spline connection. Install panels in numerical order.

Follow the Insulspan shop drawings included with the Insulspan building system. Once panels are set in position, check for plumb. Both the interior and exterior surface of panel at spline connections must be fastened as per approved Insulspan shop drawings.

If necessary, use ratchet straps to pull the panels together while tapping gently with a sledgehammer as a means of moving panels into position. Always use blocks when tapping along the edge to avoid damaging the OSB skins or exposed splines.

Always make sure to properly brace wall panels while installing them. This will make them safer to work around, and in the event of high winds, will ensure they don't fall over causing considerable damage, expense and lost productivity.

4.6. Window and Door Panel Openings Installation

Typically window openings will require 2x let-in blocking all the way around the edge of the opening. Check the window manufacturer's specifications for the rough opening size as they vary for each manufacturer.

Panels are factory pre-cut and recessed for all window and door openings. For Ready to Assemble (RTA) packages the let-in lumber is preinstalled into the window or door assembly components. The panels and/or headers that create the window or door openings are not pre-assembled in the factory. They must be assembled as per the approved Insulspan shop drawings.

The panel edges must be recessed 1-1/2" for the 2x blocking. This blocking acts both as a nail base for securing windows and interior/exterior trim. If the foam insulation was not factory recessed around the edges of the rough opening, use a foam scoop available from an Insulspan sales and service center. Install the blocking by nailing through the OSB skin with nails as per approved Insulspan shop drawings.

Headers are required over door and window openings with full-height structural framing spanning from the let-in bottom plate to the let-in top plate (**Figure 19**).

Figure 19:
Reinforced rough opening for large window

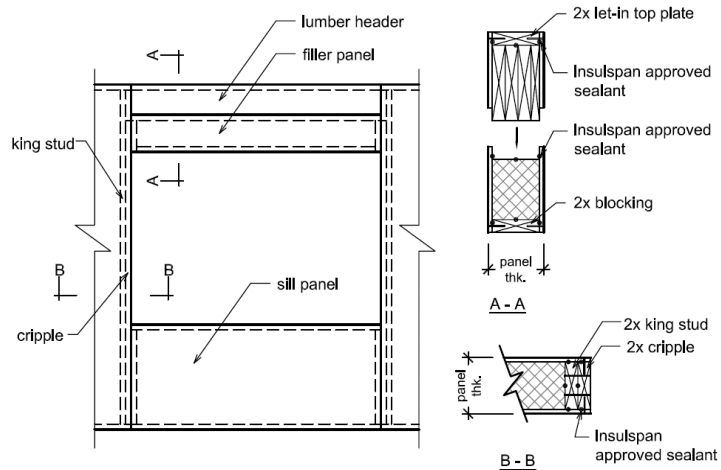

Refer to approved Insulspan shop drawings for project-specific requirements. A qualified designer must review structural requirements for compliance with local building codes.

Any specifications or special structural requirements must be provided to your Insulspan sales representative prior to the start of Insulspan shop drawings.

Unless a window opening has been cut from the center portion of a panel, the rough opening will usually consist of two side panels, a lower panel and an upper panel (**Figure 19**). Install panel adjacent to the window opening as detailed.

Apply Insulspan sealant as per approved Insulspan shop drawings. Install the panel below the window opening as detailed and pull into preceding wall panel. Position next the panel on the opposite side of window opening before installing header panel.

Lift the header above wall height and lower it down into the pockets making sure to align the header evenly with the adjacent wall panels. Nail both interior and exterior edges at all connections and along bottom plate. See Insulspan typical construction details for other options for smaller openings.

Door openings are set in the same fashion as window openings, with the header panel dropped down between the wall panels to either side.

4.7. Let-in Top Plate Installation

Check top surface of panel core for vertical wiring chases. Mark these positions on the interior OSB panel surface for later drilling reference.

Insert the 2x let-in top plate into the recess on the top of wall panels allowing a minimum offset so that the 2x let-in top plate overlaps into adjacent panels by half the panel width. Fasten 2x let-in top plate to panels using nails as per approved Insulspan shop drawings.

A cap plate is required on lower panels where there is a second floor (**Figure 20 and 21**). Apply a 3/8" continuous bead of construction adhesive or Insulspan sealant on top of the 2 x let-in top plate. Place the cap plate on the 2x let-in top plate making sure both edges of cap plate are flush with the outside wall panel skin.

Drill 1½" holes through plate(s) into the vertical electric chases in wall panel at previously marked locations.

4.8. Upper Wall Details

For multistory buildings, two details are commonly used at the transition from one wall section to the next. In both methods the panel tops are cut square and the foam is removed to accept 2x blocking.

One method involves hanging the joists from the tops of the lower panel. This is done with joist hangers with tabs that attach to the top of the panels (Simpson THA hangers or equivalent) (**Figure 20**).

Figure 20:

Joist hangers designed to fold over onto top of wall

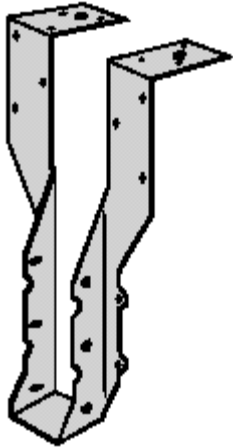

The sub floor sheathing for the second story should extend to the outside of the wall and be nailed securely to the top of the first floor wall panels (**Figure 21**).

The 2x bottom plates are then nailed around the second floor perimeter to anchor the bottoms of the second story wall panels, as described previously for wall panels that rest on floor decking (**Figures 11**).

Figure 21:

Wall-floor intersection between levels using joist hangers

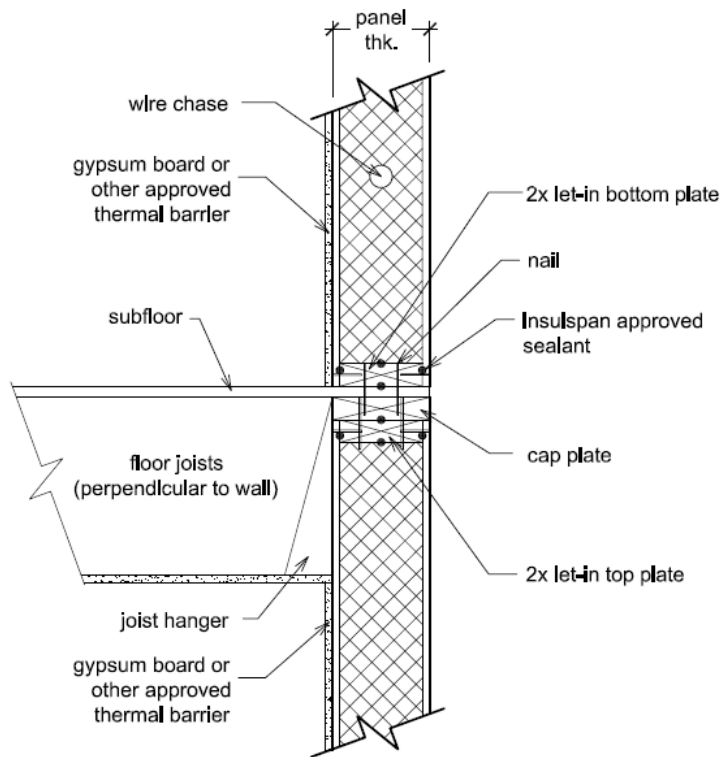

Another method uses standard platform framing where the floor deck sits on top of the lower panel walls (**Figure 22**). The joists must be securely nailed to the top plate in the SIP panel and install the upper panel over plates nailed into the floor decking. Insulate and seal tightly between the joists. Failure to do so can result in condensation at the rim board and provide an environment that is conducive to the formation of mold.

Figure 22:

Wall-floor intersection between levels with full floor deck

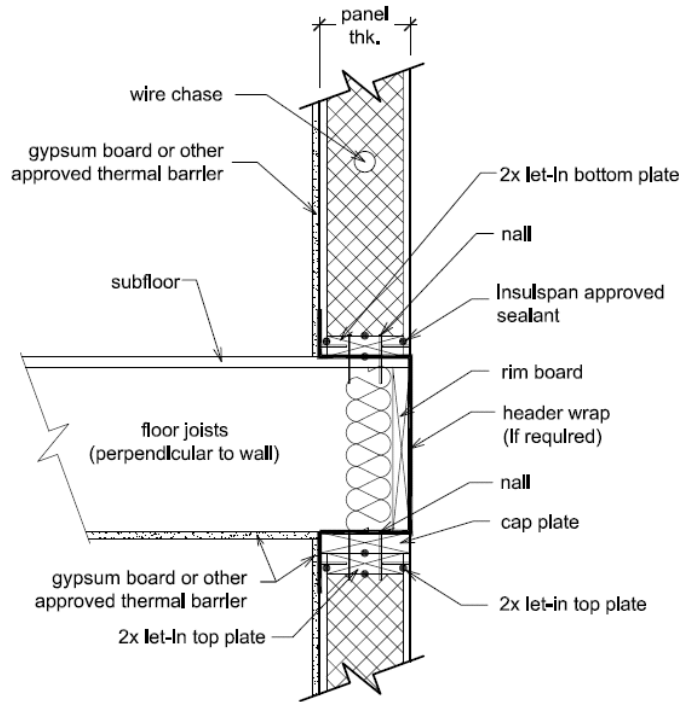

Where gable end wall panels run parallel to the floor joists and extend past the floor deck level, a ledger plate must be attached to the gable panel as shown in **Figure 23** to support the edge of the floor deck. A ledger plate fastened in this way can support the edge of a floor deck, but must not be used as a header to support other joists.

Figure 23:

Ledger at gable end wall

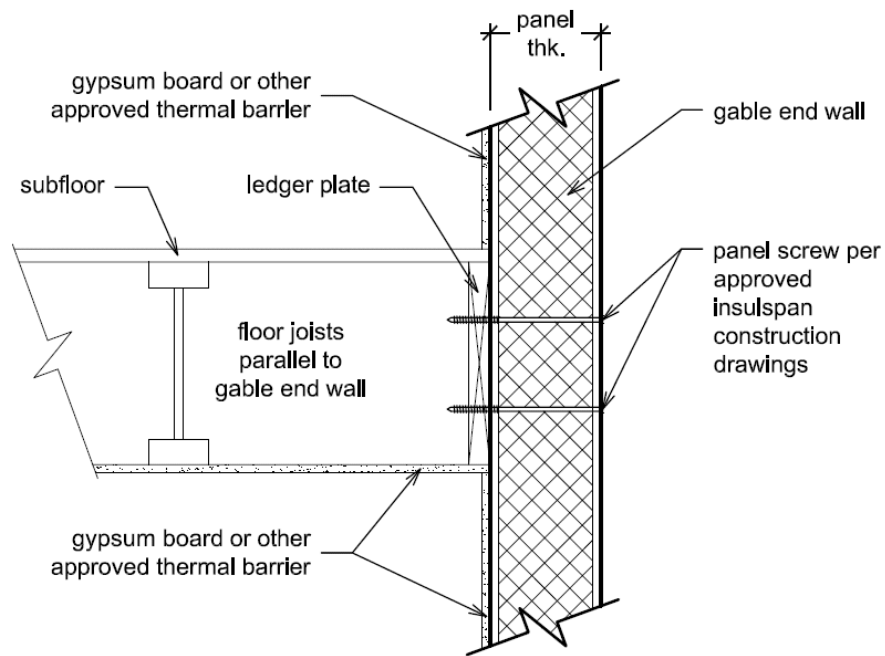

Where Insulspan wall and roof panels connect, wall panels are usually cut to match the pitch of the roof. This is done by cutting the top of the wall panel at the roof angle and inserting a let-in plate that has been ripped to match the roof angle (**Figure 24**).

Figure 24:

Blocking at eave

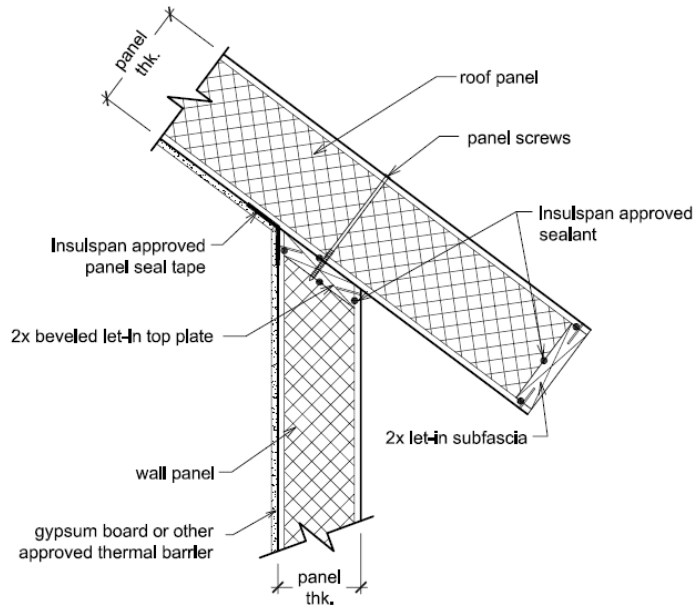

Alternatively, the panel can be cut square and fitted with a normal let-in plate and triangular blocking assembly added to match the roof angle (**Figure 25**). Care must be taken to use sufficient attachment to transfer design loads from the roof to the wall through the triangular blocking assembly.

Figure 25:

Triangular blocking at eave

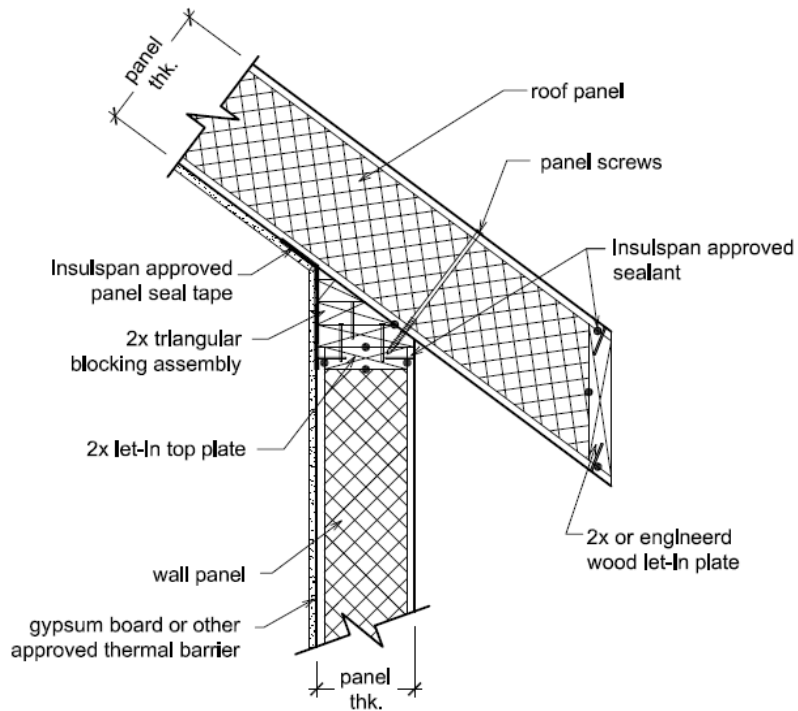

4.9. Beam Pockets

Roofs in structural panel buildings generally require ridge beams to support the panels at the ridge. Larger roofs often require intermediate supports, in the form of purlins or rafters, as well (see Chapter 5). In addition, large floor areas on upper levels may require beams for structural support, similar to stud frame construction.

Ridge beams and other heavily loaded beams are typically supported on posts of multiple 2x studs or engineered lumber. These structural beams are generally supported in beam pockets that are inset into the panels.

Posts to support the ends of structural beams are usually installed in the panel. When installed in the panels, the foam core is recessed to receive the structural posts. Structural posts must be cut accurately to length so that the beam rests directly on the end of the post (**Figure 26**) since the end grain provides higher resistance to compression.

Figure 26:
*Support for major
carrying beam*

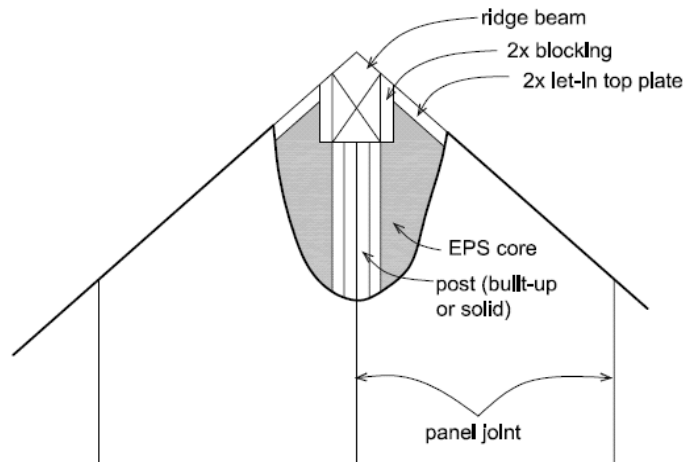

5. Roof Panel Installation Details

All of the general principals that apply to wall panel installation also apply to the installation of roof panels. These include:

- Clearing any debris that may have lodged in spline grooves or recessed areas of the panels.
- Checking OSB skins for damage.
- Repairing any damaged OSB surfaces that may become hung up on adjoining panel splines or lumber.

Before off-loading roof panels from the carrier, carefully consider where the crane will need to be positioned for easy extension. Do not block the crane's access or ability to move around the job site. Roof panels should be off-loaded and stacked in such a way that the panels are in the order that they will be installed, and placed as near as possible to their final installed position. Note: Panels may not be stacked on trucks in sequence of panel installation.

IMPORTANT NOTES:

- Roof panels will require a large area for storage and this should be prepared before the truck is on site.
- Roof panels will arrive on the job-site rough side up and should be installed this way.
- The average roof panel is between 8 ¼" and 12 ¼" thick and will weigh up to 5 lbs per square foot.
- Where roof beams and roof panels are included in the package, lifting equipment will definitely be required.
- It is the responsibility of the installer to ensure proper, safe lifting and rigging equipment is on site and coordinated to arrive at the appropriate time. There are a number of lifting techniques, which may be site specific depending on site accessibility, size of crane, panel shape, size and configuration, and weather conditions.

5.1. Before Lifting Any Roof Panels

1. Check that all wall panel top plates have been inserted and that any electrical chase ways have been drilled through the plate.
2. Check to ensure that all walls are square, plumb and braced.
3. Regardless of application - whether timber frame, log or conventional - roof panels will typically be installed above rafters, beams or purlins. Before preparing and lifting roof panels, make sure that all required structural support members are in their proper location and securely fastened.
4. Confirm roof panel measurements and actual site measurements to ensure proper fit. Roof panels may be installed parallel to the ridge (horizontal) or perpendicular to the ridge (vertical) depending on such considerations as span between supports and optimization of panels.

5. Insulspan panel seal tape must be placed over the top of all support members prior to installing panels.

5.2. Roof Panel Support Requirements

In some cases the roof SIPs will be designed to span from the eaves to a structural ridge beam (**Figure 27**). However, on larger roofs intermediate supports will generally be required, usually in the form of structural purlins (beams running parallel to the ridge). These purlins will either provide additional support for the middle of a long panel running from the eave to ridge (**Figure 28**), or they may support the joint between the ends of two shorter panels (**Figure 29**).

Figure 27:

Lifting panels onto a roof

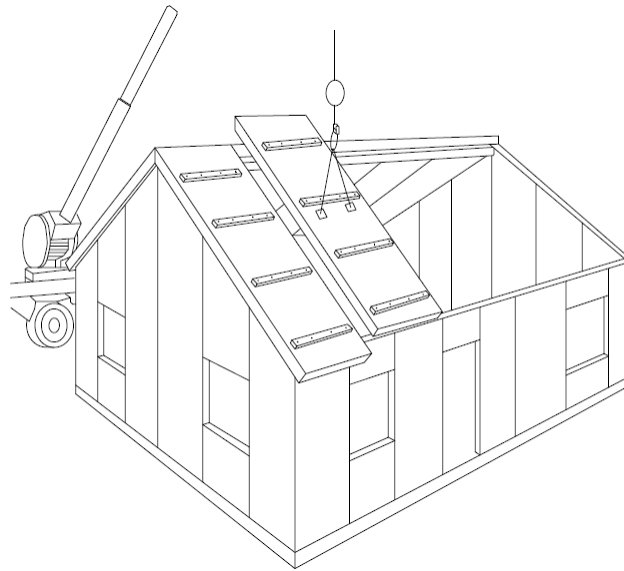
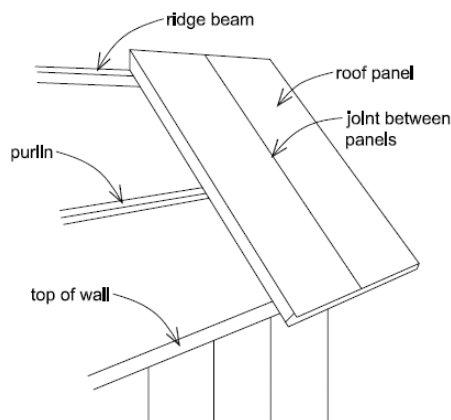

Figure 28:

Roof spanned by long panels



Note: Seal tape is not shown for drawing clarity. See Appendix "B".

The ridge beam and purlins must be installed in properly designed beam pockets with post supports and may have intermediate post supports installed as specified in the Insulspan shop drawings. In addition, temporary cross-bracing may be required to prevent flexing of the beams during panel installation.

Figure 29:

Roof with two rows of panels

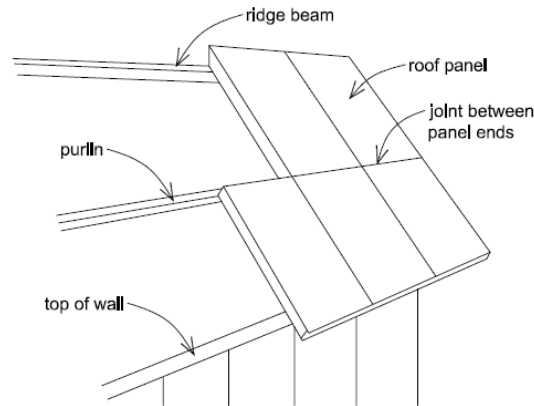

Note: Seal tape is not shown for drawing clarity. See Appendix "B".

Occasionally plans will call for rafters instead of purlins, and the panels will stretch horizontally across the roof instead of from eave to ridge (**Figure 30**).

Figure 30:

Roof with panels spanning between rafters

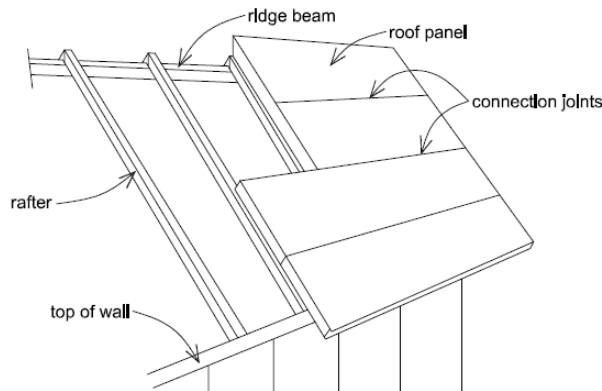

Note: Seal tape is not shown for drawing clarity. See Appendix "B".

All panel end joints must be supported with the exception of overhangs. All longitudinal panel joints must be connected with connection splines as per design requirements.

With roof panel end joints that are supported by rafters or purlins, OSB surface splines or Insulsplines are used. Each panel end must be nailed securely to the supporting member as per approved Insulspan shop drawings. When OSB surface splines are used, Insulspan approved foam sealant must be used to seal the joint.

After the panels have been placed at the time when the panel splines are fastened on the underside of panels, the panel seal tape must be secured to the OSB on each side of the support and on all roof panel seams.

5.3. Hoisting Panels

Panels can be hoisted onto the roof using various methods, but a crane is usually used to lift the panels into place. Ensure that all local health and safety regulations are met.

For most efficient use of crane time, make sure the crane operator is skilled in this kind of work—ideally someone who has worked with Insulspan panels. Also, staging the panels into the sequence in which they need to be installed can decrease the amount of crane time required. The most effective and simplest way to attach to the panels is to use steel plates screwed to the top skin of the panel that are secured with straps to the cable from the crane (**Figure 27**). Before hoisting, nail a series of 2x4s to the top face of the panel, using at least 16d nails 12" on center, to serve as footholds once the panel is on the roof. **Never let anyone stand under a panel being lifted by a crane. Lifting devices must comply with local safety requirements.**

After panels have been installed, Insulspan approved edge sealant is applied to the top edge of OSB at joints between panels (**Figures 28, 29 and 30**). The purpose of the edge sealant is to provide protection against moisture entering the exposed edges of the OSB at the joints.

5.4. Ridge Details

Note the selection of the appropriate panel joint detail at the ridge requires engineering review of load and span conditions by your designer for specific projects.

A common detail for the panel joint at the ridge beam is to bevel-cut the ends of panels to be joined at the ridge. A minimum 3/4" V-shaped gap should be left between panels at the top of the joint for sealing with two-part foam later (**Figure 31**).

Figure 31:

Panel joint at ridge beam with no let-in lumber

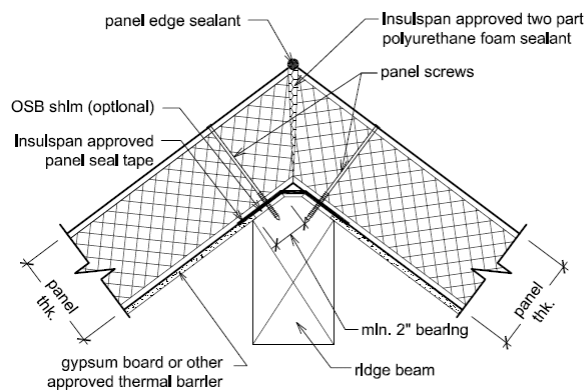

To provide structural support at the ridge, the ridge joint is usually supported by a ridge beam. Before the ridge panels are set in place, apply the panel seal tape on the ridge beam as a secondary control against air leakage.

Other options available are to overlap panels at the ridge (**Figure 32**) or plumb cut panel with 2x lumber inserted (**Figure 33**) with the panel ends cut to the corresponding roof pitch and sealant applied as shown.

Figure 32:

Panel joint at ridge beam with overlap

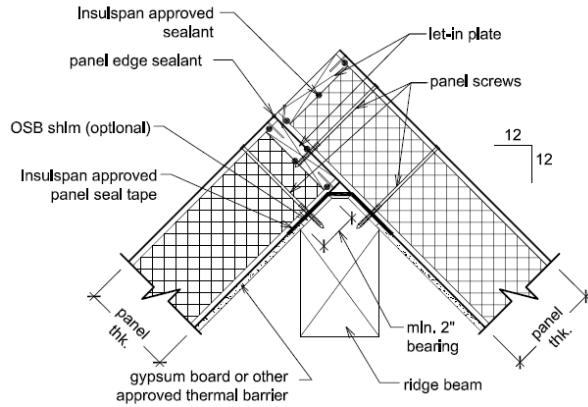
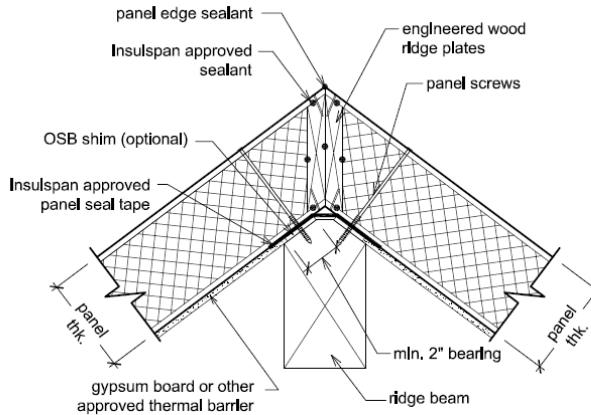

Figure 33:

Panel joint at ridge with beam with let-in lumber



When the ridge connection is cantilevered from bearing support, inset 2x splines in the miter-cut ends are used to join the panels at the ridge (**Figure 34**). Note that this detail can only be used following engineering review of load and span conditions. Consult your Insulspan designer for applicability to specific projects.

Figure 34:

Panel joint at ridge without a beam

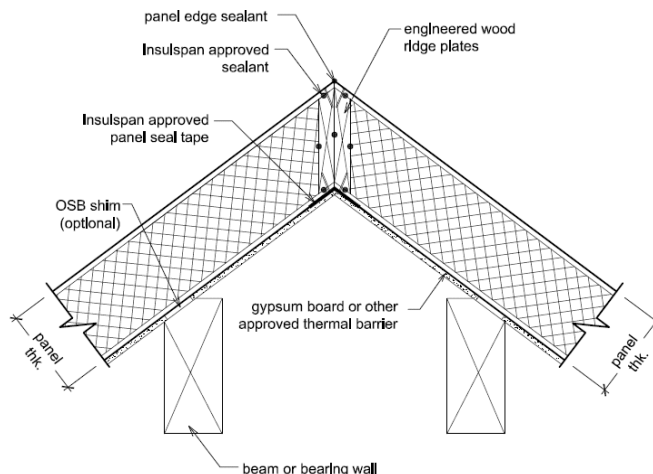

5.5. Valley Details

Valley details are essentially the same as ridge details. Panels should be miter-cut, and a minimum 3/4" V-shaped gap should be left between panels at the top side of the joint for foam sealing later (**Figure 35**). In some cases let-in lumber may be required (**Figure 36**). As with ridges, structural support is generally required under valleys. Follow Insulspan approved shop drawings and manufacturer's instructions.

Figure 35:

Panel joint at valley with no let-in lumber

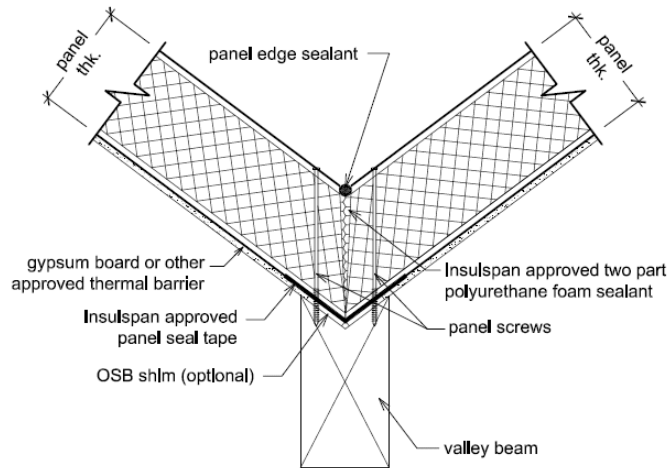
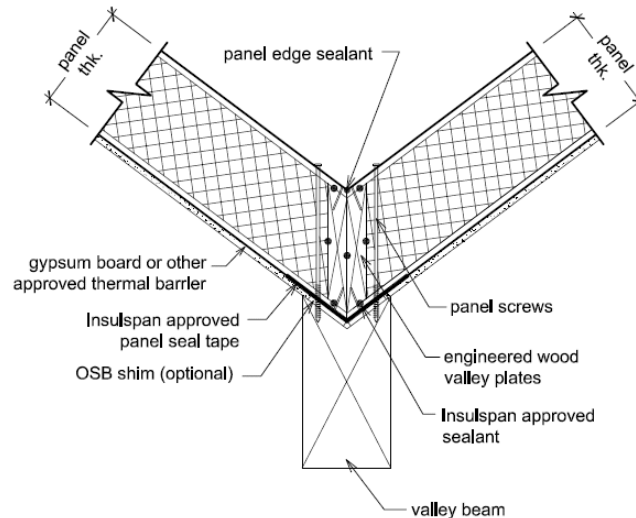

Figure 36:

Panel joint at valley with let-in lumber



5.6. Roof Overhangs

Allowable roof overhangs at the eaves and gable end depend on local snow loads, wind loads, and the type of panel used. A general "rule of thumb" is that Insulspan panels can overhang the outside of the wall panel by up to 24" if the portion of the panel not overhanging is at least twice as long as the overhang (**Figure 37**). Engineering review is required if overhang is greater than 24".

Figure 37:

*Estimating allowable
roof overhangs*

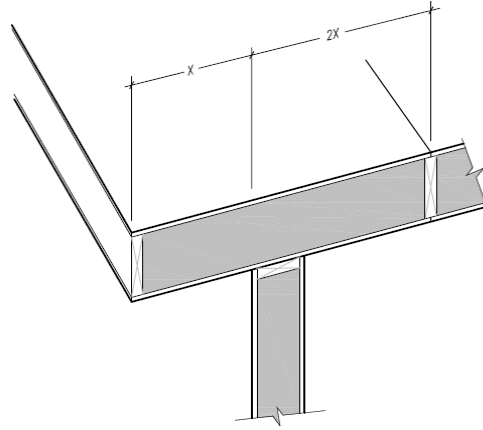

5.7. Roof Penetrations

Roof penetrations for skylights, chimneys, dormers and flues must be carefully planned relative to structural loading, air leakage and fire safety. Follow approved Insulspan shop drawings when using any penetrations.

Large openings and all chimneys should have integral structural support in the form of specially reinforced panel sections or external timber support (rafters, purlins) under the openings. Follow applicable fire codes for air spaces and sealing around chimney and flue penetrations (**Figure 38**).

Figure 38:

*Opening for large
skylight*

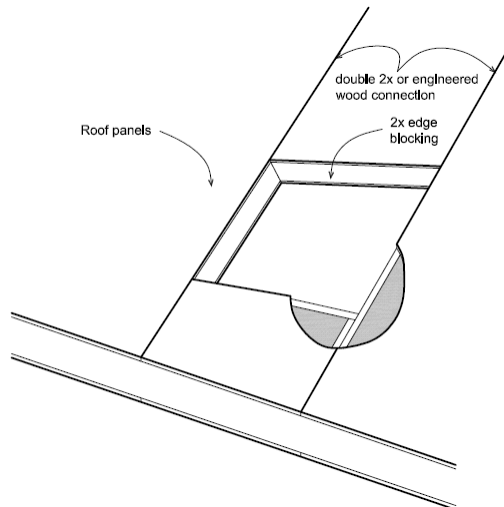

For roof penetrations less than 24" by 24", the panel edges at all major roof penetrations must be reinforced with 2x let-in blocking (**Figure 39**).

Roof vent penetrations must be carefully planned relative to air leakage and fire safety (**Figure 40**). The maximum penetration for vents is 6" round with no blocking. Vent openings larger than 6" require blocking.

Figure 39:
Opening for small skylight

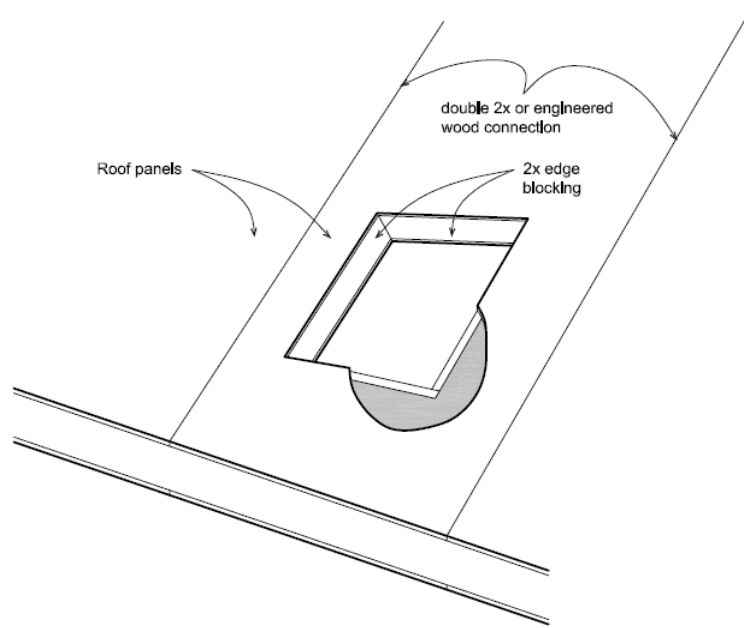
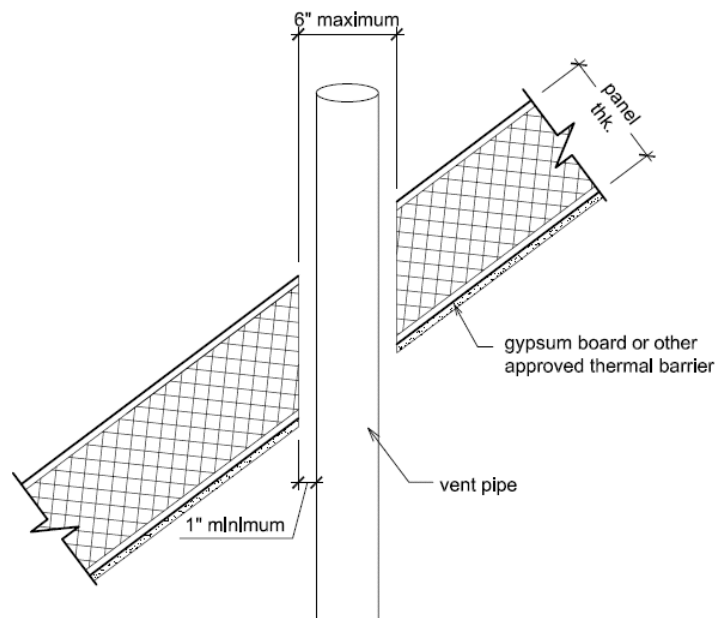
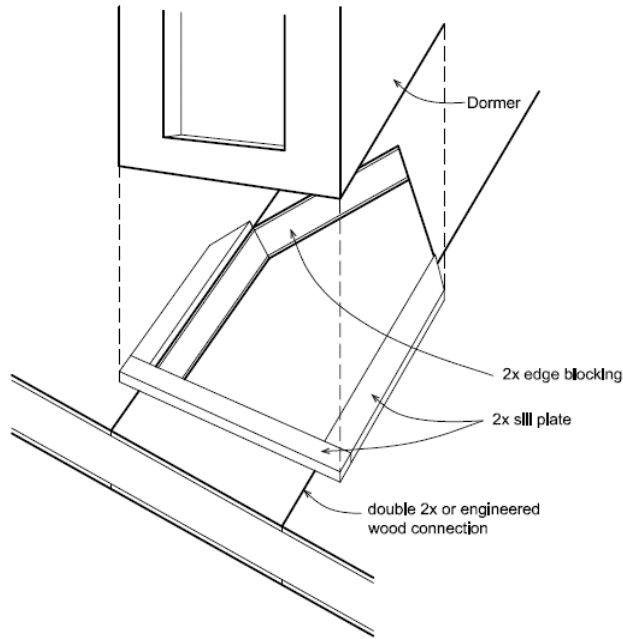

Figure 40:
Round stack vent penetration



Roof openings for large dormers must be reinforced with 2x let-in blocking around the opening and with structural beams under the panel. Dormers are attached directly to the bottom plate that is attached to the exterior OSB surface of the roof (**Figure 41**). The routed bottom edge of the dormer panels are fit over 2x bottom plates that are glued and nailed to the roof panels, as shown. Nail the dormer into the bottom plate from both the interior and exterior of the dormer.

Figure 41:
Installing a large prefabricated dormer



Roof openings for small dormers must be reinforced with 2x let-in blocking at the edge of the opening (**Figure 42**).

Figure 42:
Installing a small prefabricated dormer

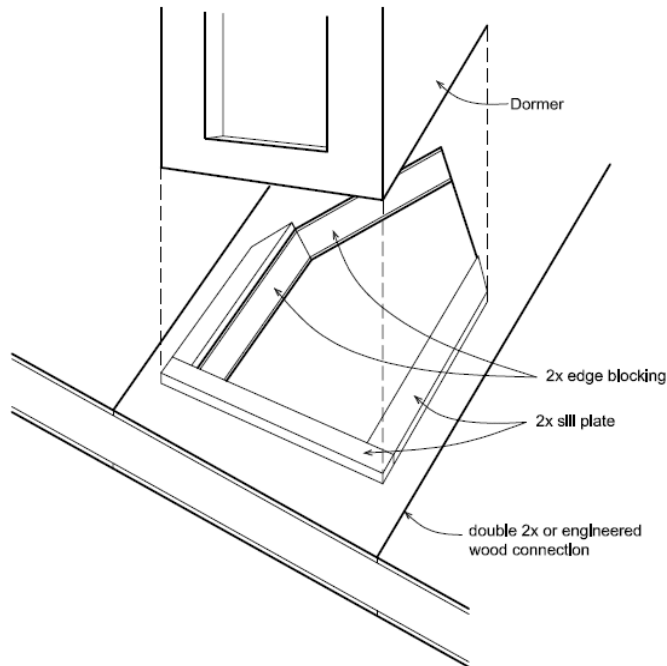

All sills, blocking and splines must be carefully sealed with Insulspan approved sealant (**Figure 43**).

Figure 43:

Vertical sections through dormer roof junction

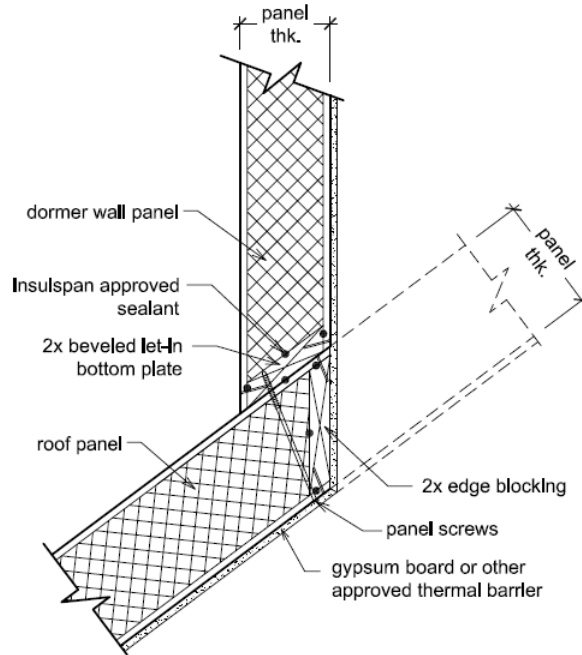

5.8. Eave and Gable End Finishing Details

Roof panel edges can arrive routed for 2x let-in blocking. After panels are installed, this blocking is inset along the entire roof edge—along both eaves and rakes (**Figure 44**). To adequately reinforce panel joints at the roof edge, no blocking should end within two foot (2') of a panel joint. With square-cut panel edges at the eaves, standard dimensional lumber is used. If the panel edge is plumb-cut, specially ripped blocking must be inset. The cutting and routing of plumb-cut roof panels can be difficult and will require special attention.

Figure 44:

Edge blocking of roof panels

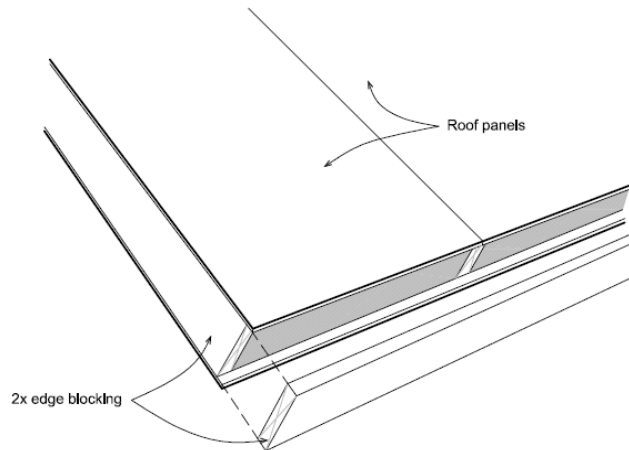

After edge blocking is inset, the panel edge should be protected with trim boards (**Figures 45 and 46**). Fascia boards should always be used. Vented soffits are required whenever there is an enclosed overhang. The trim detail can be ornate or simple to suit your needs.

When choosing which trim detail to use, take into consideration optimal panel length—some details require that the roof panels overhang the wall farther than others.

Figure 45:

Roof trim

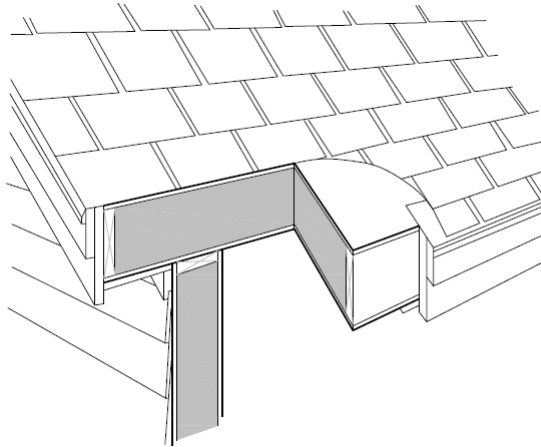

Figure 46:

Alternate Roof Trim detail



6. Floor Panel Installation Details

Insulspan structural panels can also be used to create an insulated floor over a crawl space (**Figure 47**) or on piers (**Figure 48**). Check with your manufacturer for the allowable spans of each thickness panel for your loading needs. Single 2x splines should be inset into the edges of the deck to support walls above.

In certain cases double 2x splines should be inset into the edges of the deck to support walls above with higher axial loads and/or structural posts requiring large bearing area in the floor panel. Check with your Insulspan design representative.

Figure 47:
*Floor panel over
crawl space*

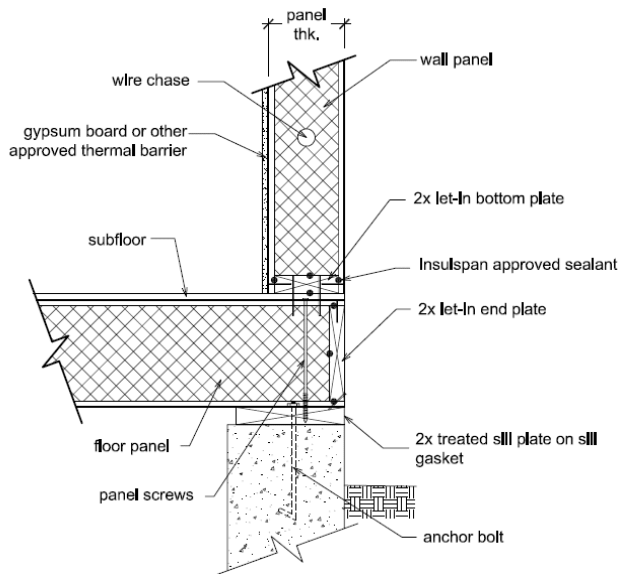
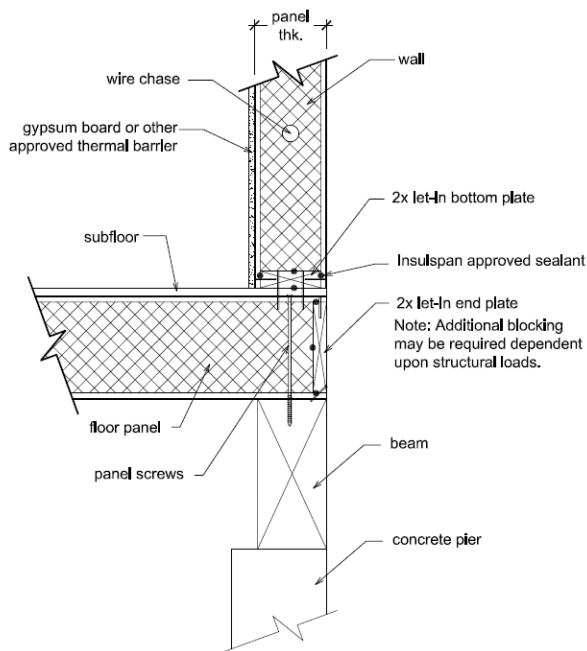

Figure 48:
*Floor panel over
piers*



7. Wiring and Plumbing

Wiring and plumbing requirements can be easily accommodated if pre-planned as part of the design process.

7.1. Wire Chases

Factory pre-routed wire chases can be requested when placing your order. For wall panels, typically two horizontal wiring chases are cut into the core. The standard heights from the floor deck for these two horizontal chases are 14" and 44" (**Figure 49 and 50**).

You may require custom wire chases according to your plans.

There also can be a vertical chase in each panel, as specified in your Insulspan shop drawings. These wiring chases are 1-1/2" in diameter and centered between inside and outside panel faces.

IMPORTANT NOTES:

1. Do not use recessed lighting fixtures in foam core panels.
2. Do not cut the Interior or exterior OSB skin for horizontal access as this will reduce the structural integrity of the SIP wall panel.

Figure 49:
*Wiring chases in
drop wall panels*

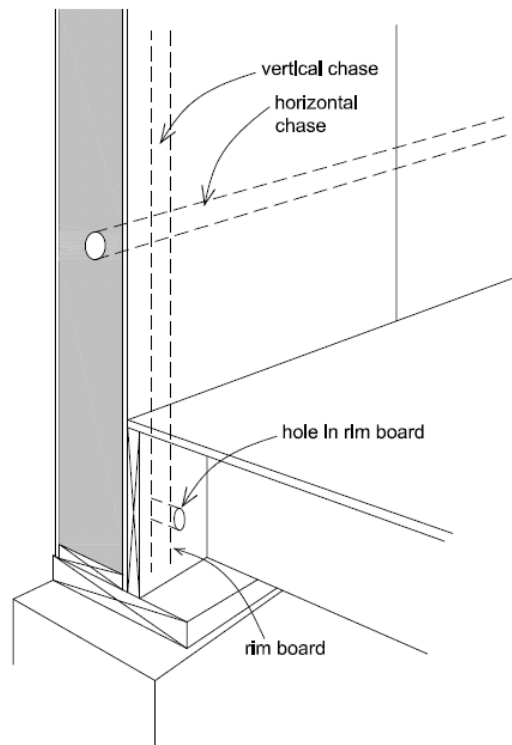
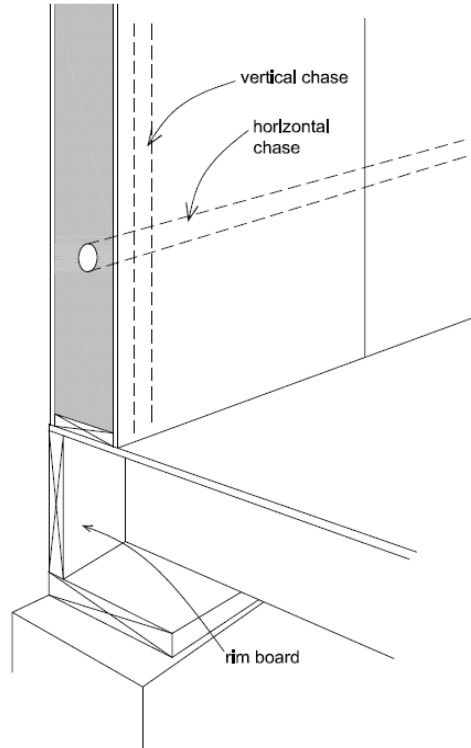

Figure 50:

Wiring chases in wall panels sitting on floor deck



Because the horizontal wiring chases are in standard locations relative to the floor deck, wiring is very easy. The vertical chases extending through the full panel make it easy to wire wall sconces and wall switches. To make it easier to install switches next to doorways, the edge blocking that reinforces the perimeter of the rough opening can often be temporarily installed until after the electrician has finished rough wiring (**Figure 51**).

Figure 51:

Doorway jack stud removed to allow wiring into switchbox

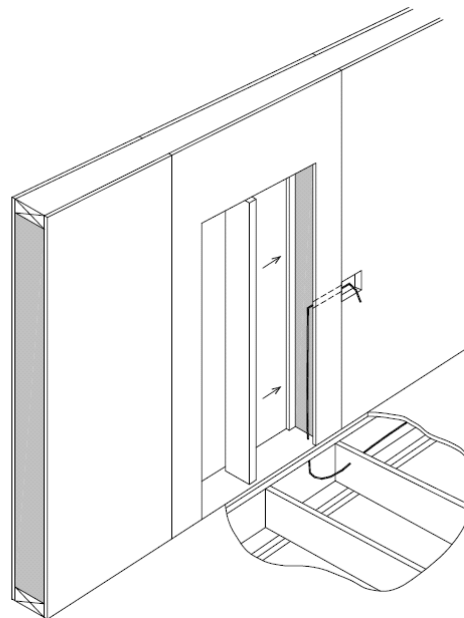

7.2. Receptacle Boxes

Receptacle boxes should be installed at standard height just above the horizontal wiring chase.

To install the boxes, mark outline on inner panel skin and cut through inner skin(s) with a router or saw. Remove the foam out to the depth of the box, allowing for interior finish of the walls (**Figure 52**). All cutouts into panels for receptacles should be made before beginning to run wires to avoid damage to wires. After supplying wires to the location, secure receptacle boxes with straps or other surface-type fasteners. Also, just before final positioning of the electrical box, seal the wire chase by filling with expanding foam sealant.

Figure 52:

*Positioning
receptacles*

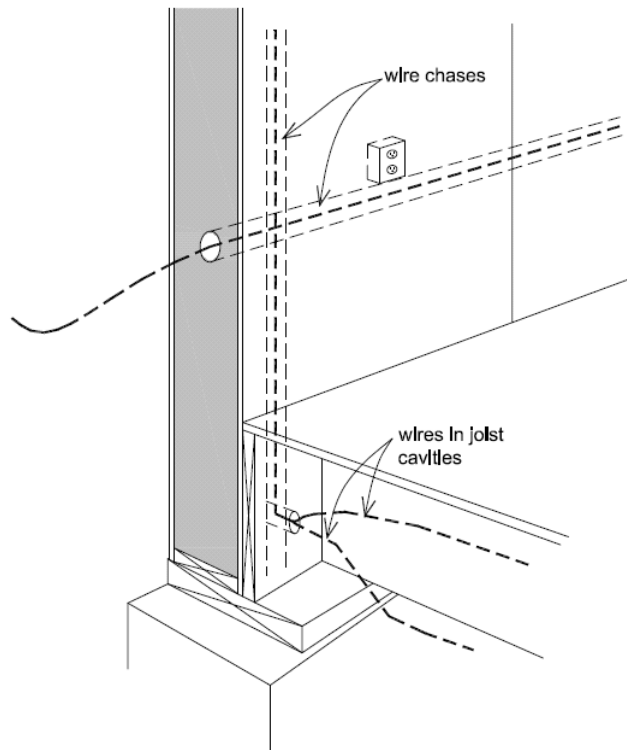

If the wall panels rest directly on the floor deck, the electrician can access the chases from the bottoms of the panels by drilling through the sub-floor on which the panels are resting (**Figure 53**). This task is greatly simplified if the frame carpenter drills access holes in the sub-floor below the vertical channels before the panels are installed. (**Figure 14**)

Figure 53:

*Access hole from
basement to wiring
chase*

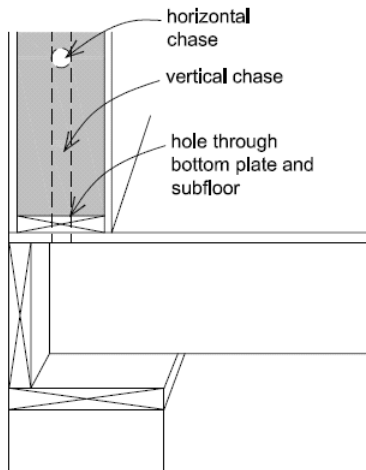

If wall panels extend all the way down to the foundation, the electrician will have to drill through the band joists into the wiring chase from inside (**Figure 54**). These holes can be drilled before the panels are installed to simplify the process of locating them to line up with the wiring channels.

Figure 54:

*Access hole through
panel wall*

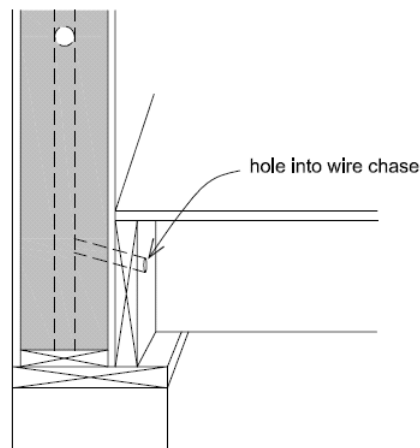

Bring wires up from the basement directly under a receptacle box, so that the wire can be pulled straight up. Horizontal wiring runs can then extend from that point. Keep major wiring runs in the basement to avoid filling up the wiring chases in the panels.

An alternative to running electrical wires in the panels is to incorporate chases for them in the baseboards. One way to do this is to build out the baseboard with furring strips (**Figure 55**). If the drywall is cut off above the strips, the baseboard will not stick out noticeably. A quarter-round or other molding can be used to cap the baseboard and hide the furring strip. In some areas electrical outlets can also be installed in the base-board. **Doing so may violate local electrical codes, so check it out with your inspector before proceeding.**

Figure 55:

Electrical chase behind baseboard

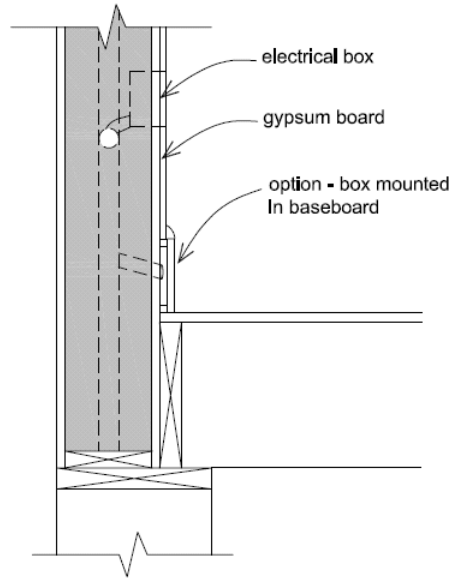

7.3. Plumbing Lines

Plumbing lines in exterior walls are never a good idea, and panel walls are no exception. If vertical plumbing run cannot be accommodated in the interior walls, building a separate plumbing chase is a good alternative (**Figure 56**). A chase can be an attractive way to hide pipes without any risk of freezing.

Figure 56:

Plumbing chase next to exterior wall

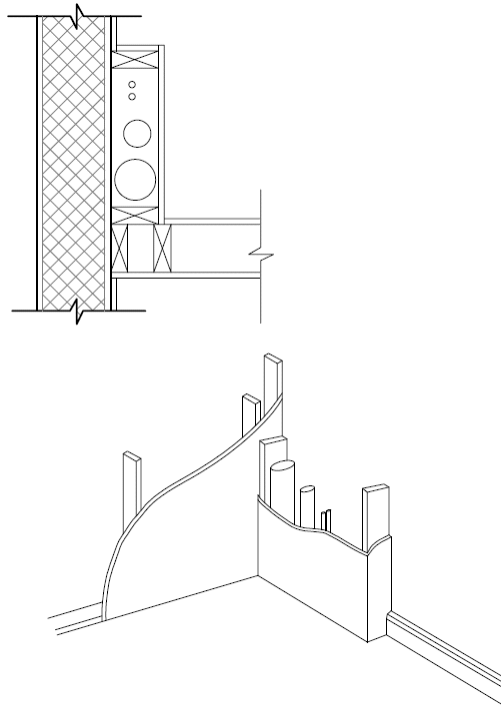

8. Special Sealing Details

Sealing of windows and doors, wall intersections, and ridges is mandatory in all climate conditions. For timber frame applications, all gaps between wall and roof panels may be filled with approved Insulspan two-part polyurethane foam sealant before siding and roofing. In addition to foam gaps which are specifically included in the design and shop cutting of panels, gaps of varying sizes may occur due to variations in materials and the supporting structure on which the panels are installed.

Clearly label gaps or voids which cannot be seen after panels are in place in bold letters as the panels are being installed to help ensure that they will not be missed when final inspection and sealing of the panels is completed. Then, as time permits, methodically seal all gaps and mark gaps as properly sealed. Gaps that are 1/4" wide or smaller can be sealed with a bead of approved Insulspan Sealant. Gaps that are wider than 1/4" must be sealed with expanding foam. With expanding foam, insert nozzle of foaming can or gun into the gap and apply a heavy enough bead so that the foam nearly reaches the outer skin before curing, (it will take some practice to apply just the right amount of foam). (**Figure 57**)

Figure 57:

Sealing gaps between wall and roof panels

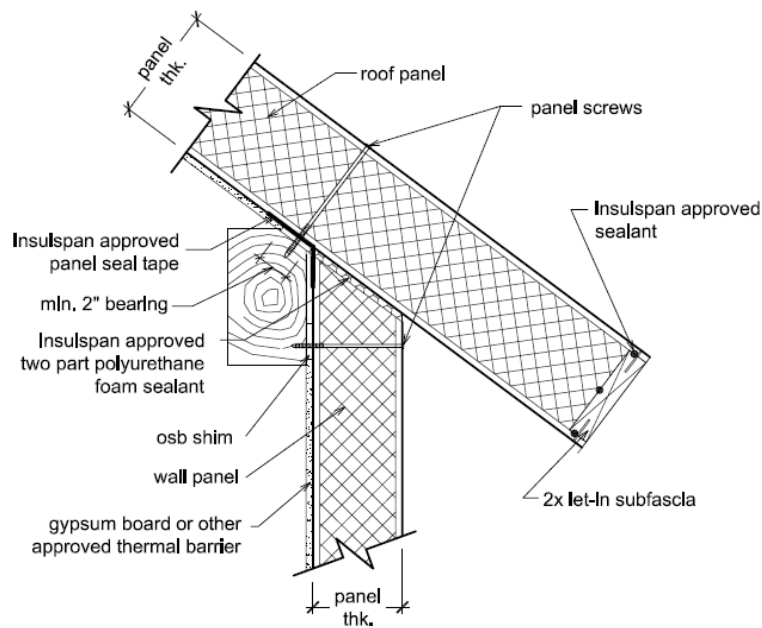

For certain applications, with no gap between wall and roof panels with let-in lumber, approved Insulspan sealant must be applied. (**Figure 58**).

Figure 58:

Sealing between wall and roof panels with let-in connection

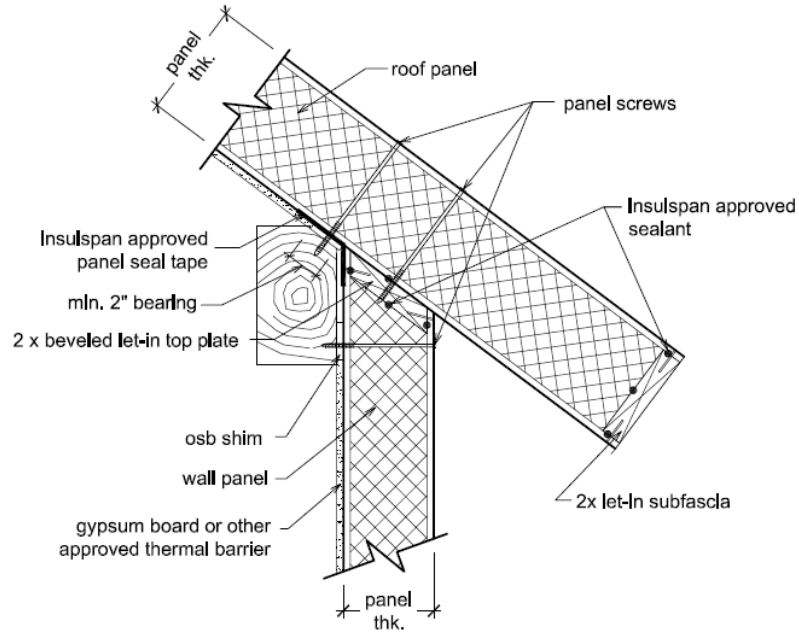

Also special low expanding foam (not supplied by Insulspan) should be applied between window or door jambs and panel rough openings. The low expanding foams will not push window and door jambs out of alignment. Make sure the bead of foam is continuous around the entire window or door, which may require pushing the foam nozzle behind shims and then reinserting from the other side of the shim (**Figure 59**). It is also recommended to seal electrical chases where possible in order to improve the air-tightness of the building envelope.

Figure 59:

Sealing around door

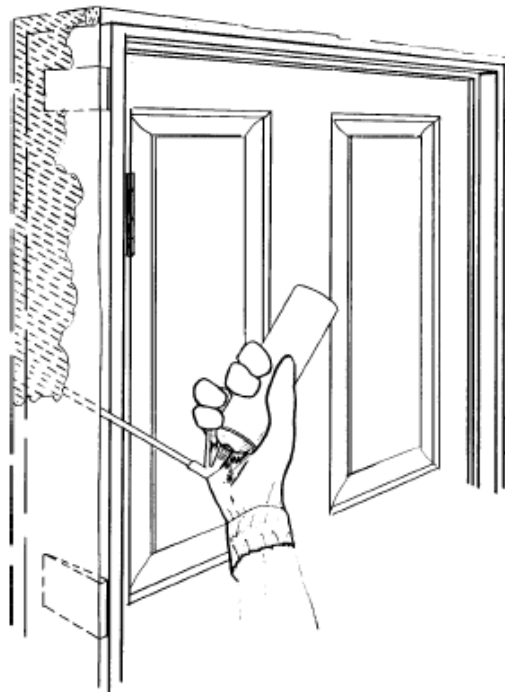

9. Exterior Finishing – Wall and Roof Applications

IMPOTANT NOTE: The Insulspan SIP system must be protected from exposure to rain, prior, during and after installation. Long-term performance of the Insulspan SIP system depends upon continuous protection from water penetration for the projected lifetime of the structure.

Oriented strand board (OSB) used in the Insulspan SIP System meets requirements per US DOC PS2-04, (**Performance Standard for Wood-Based Structural-Use Panels**) and CAN/CSA–O325.0-92, (**Construction Sheathing**) for Exposure 1 and exterior grade sheathing. Exposure 1 or exterior grade sheathing classification means that the OSB panels are suitable for uses not permanently exposed to the weather. This classification means limited exposure to moisture due to short-term construction delays, or conditions of similar severity, will not affect OSB structural performance properties.

9.1. Rain Penetration Control

Long term performance of the Insulspan SIP system depends on continuous protection from water penetration for the projected lifetime of the structure. In conventional wood frame structures when a failure of the roof or wall cladding occurs, water would normally leak into the occupant space. By this leakage, the occupants are alerted to this failure and repairs can be undertaken.

In the case of closed panels, such as SIPs, the occupants may not be alerted of any water penetration until the exterior OSB skins have absorbed excessive moisture increasing the risk of failure. The use of wet OSB is not permitted; hence, conditions that result in wetting of the OSB must be avoided by the cladding design.

Both wall and roof cladding must be installed with a ‘second line of defense’ against water penetration in line with the occupant expectations of performance and maintenance envisioned.

9.2. Wall Cladding

A weather resistant barrier such as building felt or Insulspan house wrap (sheathing membrane) is required on the outside of walls. The barrier must be installed in a fashion to form a drainage plane to shed any water which penetrates the exterior finish materials.

Wall cladding installed as a rainscreen system requires a minimum 3/8" air space to allow for drainage of any water that may breach the cladding. The 3/8" air space for drainage shall be outboard of the sheathing membrane protecting the SIP panel. The membrane shall be properly installed in conjunction with top and bottom window flashing to shed water to the exterior.

Ring shank siding nails are generally recommended for nailing siding to the OSB exterior sheathing. It is not recommended to install cedar siding or trim over

Insulspan house wrap as the natural tannins in the cedar can degrade the water repellency of the wrap. Instead, use building felt.

With board-and-batten siding, strapping is recommended. Apply strapping horizontally (usually 16" on center). Be sure to account for the thickness of the strapping in planning window and door jambs, sills, etc.

9.3. Roof Cladding

The strength of conventional roof structures, whether they consist of roof trusses or roof rafters, are largely unaffected by the initial stages of any water penetration. In the case of SIPs, failure of the roof covering could lead to rapid accumulation of moisture in the top skin accompanied by changes in the performance of the panels and, likely, permanent sagging of the roof panels.

For this reason, the design of roof cladding used with SIPs must provide a reduced risk of water penetration as compared with conventional roof structures. The roof cladding installed shall have a second line of defense based on the anticipated wind-driven rain, snow and ice condition for the geographical location.

Examples of a second line of defense include, single or multiple layers of 15 lb or 30 lb or modified bituminous membranes. The selection should be based on the climatic loads at the building location, anticipated roof slope, quality of the roof cladding selected and occupant performance expectations and maintenance envisioned. Care must be taken during roof panel installation where the roof panels have been exposed to moisture. OSB facers on Insulspan SIPs that have been wetted cannot dry towards the attic, as in conventional construction; therefore, if the exterior face of the Insulspan SIP System has been wetted, it must be allowed to dry before asphalt shingles or other roof cladding systems are installed.

Before proceeding with roofing, go over the roof and cut off any hardened foam sealant that protrudes above the roof surface. Also check for any moisture damage or OSB edges that have become swollen from rain. Swollen edges can be sanded down with a belt or disk sander.

A light colored, heavyweight or textured shingle is recommended to minimize ridging that can occur at panel joints. With wood, tile, or slate shingles, strapping may be required on top of the panels. Apply strapping horizontally in standard fashion as per shingle manufacturer's recommendation, and be sure to take the strapping thickness into account when planning the roof edge trim.

Do not use any heat devices to remove snow or frost, as this could melt the foam around the screws and compromise the insulation value of the roof.

IMPORTANT NOTE: Roof cladding application must be scheduled immediately after the installation of Insulspan SIP roof to avoid wetting of the exterior face. Trapping moisture between the panel seal tape applied to the underside of panel joints and roof cladding system can cause long term structural and durability damage to the Insulspan SIPs.

9.4. Interior Wall and Ceiling Finishing

Recommended techniques for finishing interior walls and ceilings depend on the finished material you use. Hang the drywall in a manner which offset the drywall panel joints with Insulspan SIP joints.

Interior partition walls may be required to be fastened to exterior SIP walls. Insulspan approved shop drawings will identify locations where this is necessary. Panel screws should be applied from the outside prior to installing the siding (**Figure 60**).

Figure 60:

*Partition wall to SIP
wall connection*

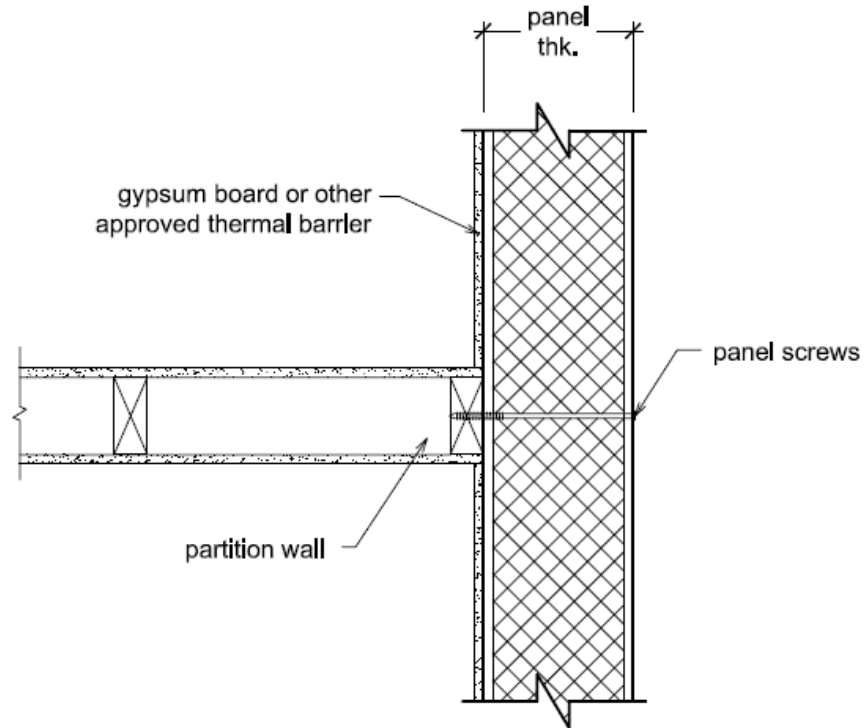

Appendix A - Applying Expanding Foam Sealant

1. General

Before using this product, review the detailed operating instructions provided by the foam sealant manufacturer including requirements for safe handling and storage equipment.

Insulspan foam sealant is a two-part expanding polyurethane foam with high expansion and quick curing. A typical curing time for expanding foam sealant is 3 to 4 minute range depending on temperature. The units are self contained in the sense that no other components are required for the foam to expand and cure.

The chemistry of the foam formation is sensitive to temperature and the ratio in which the two parts are combined. When the foam expands and sets properly, it will adequately prevent the flow of air through a seam between panels and minimize the chance for moisture to be transported through the panel seams. **Note: Expanding foam should be applied following the installation and inspection of the electrical, so as not to inadvertently fill any electrical chases.**

2. Application Instructions

The following are suggestions specific to the use of this product with the Insulspan SIP system for successful use of this product:

- 1) A vinyl tube can be added to the tip of the nozzle to assist in reaching hard to reach places such as the bottom of ridge cuts. Suitable hose can typically be purchased at any hardware store.
- 2) Insulspan foam sealant expands inside the joint cavity. Since the installer cannot see how much foam is injected into the closed cavity, care is required to ensure the expanded foam does not “blow out” or push the joint into misalignment. It is recommended that foam be applied with “breather holes” every 12” to 18” (300 to 450 mm) along the joint to reduce foam pressure. Before starting the joint sealant application drill holes along panels joints at 12 to 18” apart (depending on temperature – closer together in cold weather).
- 3) Spray the Insulspan foam sealant into every other hole for 4 to 10 seconds depending on the temperature and how much foam remains in the tank. Make sure that foam expands out of the middle (breather) holes. If foam sealant does not expand out of the middle holes then you will need to increase the length of time that you spray foam sealant into the holes.
- 4) After the foam sealant has cured, go back and drill new holes near the middle holes where expanded foam was not seen and drill new holes between the previously used holes to determine where the foam sealant stops. Follow above instructions to ensure expanded foam fills the entire joint space.
- 5) If you suspect that the foam has not set up in the seam, drill test holes along the panel joint to confirm. If the Insulspan foam sealant appears to have completely collapsed, new foam can be put in the existing holes. (Note: Make sure you do a

- test shot from the next Insulspan foam sealant tank before you start spraying into the seam)
- 6) Insulspan foam sealant should be applied when the ambient temperature is between 60 to 90 F (16 to 32 C). For best results the tank contents should be at 75 F (24 C) or warmer. Insulspan foam sealant can be applied effectively in cold air temperatures or on cool work surfaces (above freezing) provided the kit contents are at least 75 F (24 C). However, use in cold weather requires special care.
 - 7) Watch out for the following:
 - a) Cold tanks are a concern. The temperature indicator on the side of the tank shows the temperature of the contents of the tank, not ambient air temperature. For best results the tank contents should be at 75 F (24 C) or warmer.
 - b) Breather holes drilled in the panel joints may need to be placed closer together when working in colder temperatures.
 - 8) Methodically foam each seam so that every seam with OSB splines and every open seam is adequately foamed.
 - 9) Apply the foam in dry conditions and to dry materials. **DO NOT** apply the foam in wet conditions or to wet materials. Water will cause the propellant to disintegrate and prevent proper expansion and curing.
 - 10) Some general notes regarding the dispensed foam are:
 - a) If dispensed foam is friable or brittle, the foam is ISO rich, and a partial blockage of the POLYOL side exists. Clear the blockage from the POLYOL side.
 - b) If dispensed foam remains soft or mushy, the foam is POLYOL rich and a partial blockage of the ISO side exists. Clear the blockage from the ISO side.

3. General Storage and Handling Notes

Store Insulspan foam sealant at 75 F (24 C), in a clean dry area. **DO NOT STORE AT TEMPERATURES ABOVE 120 F (49 C)**. Avoid prolonged storage in direct sunlight or near heat sources. Store a partially used kit with the safety ON (do not tie trigger down) and valves CLOSED. Remove used nozzle, reapply petroleum jelly to face of the dispenser, and reinsert the used nozzle prior to storing. Do not bleed pressure off hoses during storage.

When the kit is ready to be reused, remove the old nozzle from the gun and insert a new nozzle. **NEVER** reuse a “spent” nozzle (that had chemical previously sprayed through it). The chemical will backfire into the gun. This will cause the chemical to set up in the hose, causing the entire gun hose assembly to be unusable.

Appendix B - Panel Seal Tape Installation Instructions

1. Background

The use of Insulspan Panel Seal Tape at all roof and roof to wall panel connections is an important step to ensure the durability of the Insulspan roof panels. The reason for using the Panel Seal Tape is to provide an additional layer of protection to prevent airflow through panel joints. Airflow from a relatively warm moist environment to a cooler and dryer environment often results in condensation of moisture on the cool side of the panel. The moisture can accumulate over time and lead to deterioration of the panel skin and reduction of structural integrity at the location of deterioration. Proper installation of the panel seal tape along with sealing of the joint per the Insulspan Installation Manual will minimize the chance for a problem to develop. Please carefully read and follow these installation instructions.

IMPORTANT NOTE: Most panel failures are a result of moisture intrusion caused by failure to properly seal the SIP joints. Insulspan SIP joints must be sealed using Insulspan approved sealant and Insulspan approved panel seal tape. Protect yourself from problems and expense by installing these products correctly.

2. Surface Preparation

All surfaces must be clean, dry and free of dirt, grease, oil and any other contaminants that may interfere with adhesion. Any panel damage must be repaired prior to installing tape.

3. General Tape Installation Tips

The tape should be positioned so that it is centered over panel joint. Peel off several inches of release backing and press firmly into place. To ensure a tight seal and minimize air bubbles and wrinkles, tape should be pressed into OSB at the center, working outward with a smoothing motion to the edges. After tape has been installed, any wrinkles and bubbles must be removed with a roller or similar tool with adequate hand pressure to firmly attach the tape to the OSB surface.

The tape width should be chosen to provide a minimum of 2-1/2 inches of adhered surface on each side of the joint and/or bearing support.

4. Panel Joint Sealant Tape Location

The map to the right provides general guidance for panel seal tape location. For instance, if the structure is located in the UNSHADED areas of the map, panel seal tape would generally be applied on the INTERIOR side of roof panel joints and roof-to-wall joints. In SHADED regions, panel seal tape would generally apply on the OUTSIDE of roof panel joints and roof to wall joints. However, application of panel seal tape should always follow local building code requirements.



5. Installation Sequence

5.1. Prior to Roof Panel Installation

Prior to panel installation apply panel seal tape to top of bearing supports such as rafters, purlins, and interior walls whenever a panel joint is directly over a bearing support or wherever a panel joint crosses a bearing support as follows:

- 1) Apply the panel seal tape so that it extends beyond the edges of the bearing support by a minimum of 2-1/2 inches on each side of the support.
- 2) Apply the seal tape with the release paper side up.
- 3) Attach the seal tape to the bearing support with staples or roofing nails in sufficient quantity to ensure that the tape will not blow off prior to panel installation.
- 4) Do not remove the release paper until panels have been installed.
- 5) Be careful to align the tape with the support to maintain the minimum (2-1/2 inch) overlapping on each side.
- 6) Use care in the application to prevent the tape from having open punctures. The tape will self-seal around staples and nails. Other punctures must be repaired or the tape replaced. The release paper removed a minimum of three inches away from the puncture and a new piece of undamaged tape adhered to that section to repair a puncture.

5.2. Fully exposed seams

Install panels following Insulspan approved shop drawings. Apply all specified fasteners and sealant to joint. After removing any surplus sealant or loose debris from surface of OSB (make sure OSB is dry):

- 1) Using a minimum of 6-inch wide tape, peel back a section of release paper and center tape on the joint and adhere to the OSB by applying firm pressure with your hand. Be careful to align the tape with the joint so that the tape does not run away from the joint.
- 2) If the tape becomes more than one inch off center, then cut the tape at the point it went off center. Restart the tape by overlapping a new piece of tape at least 2-1/2 inches from the point where the tape went off center.
- 3) At locations where panel joints intersect, overlap the panel seal tape by a minimum of 2-1/2 inches. The sequence of adhering intersecting tape is not critical for interior applications. When the site location requires application to the exterior of the roof panel, the tape should be installed shingle fashion down the roof.

5.3. Concealed seams

Concealed seams typically occur over bearing supports. At locations where open seams intersect interior bearing points, such as rafters, purlins or walls, overlap the tape a minimum of 2-1/2 inches with the tape that was installed over the bearing locations per item 2 in section 5.1 prior to roof panel installation.

5.4. After Panel Installation

Apply panel seal tape prior to heating structure or application of interior finish material at all locations that seal tape was installed over top of bearing supports as follows:

- 1) Wipe or brush away any loose debris from the OSB where the tape will be adhered.
- 2) Separate tape and release paper and let release paper hang down.
- 3) Using a knife, cut the release paper close to the support and remove the release paper. Be extremely careful to only cut through the release paper and not through the tape.
- 4) Attach panel tape to both sides of the support by applying firm pressure with your hand and/or roller along the entire length of the tape.
- 5) Repair all wrinkles in the tape as described in General Installation Tips.

5.5. Roof-Wall Intersections with Support Members

For Roof-Wall intersections that have a support member which blocks the intersection (Example: where a timber rafter or plate forms a connection between the wall and roof):

- 1) Apply the seal tape to the top 3 inches of the face of the panel by removing a 3-inch wide section of the release paper and adhering it to the face of the panel (interior face for the northern installations and exterior face for southern installations) prior to installation of wall panels. Allow for 3-inch overlap at each side of panel.
- 2) Install the panel and attach to support member as detailed on drawings. Use care to insure that only the tape, which is adhered to the panel face is between the wall and panel support.
- 3) Lay the loose tape over top of the support member and insure that it extends past the support member a minimum of 3 inches to allow for it to be adhered to the roof panel.
- 4) At the ends of the wall panels where the tape overlaps, remove just enough release paper to permit the adjacent tapes to be adhered across a 3-inch width.
- 5) Attach the tape to the top of the supporting member with the roof nails or staples in sufficient quantity to ensure that tape is not damaged by wind prior to roof panel installations.
- 6) After panels have been applied, secure the panel seam tape to the underside of the panel as described above.



Highland Environmental Education
& Lodging Complex

Residential • Multi-Unit • Commercial • Institutional

Better building ideas from PFB ™

INSULSPAN®
STRUCTURAL INSULATING PANEL SYSTEM